

# INSTRUCTION SHEET

## ELECTRONIC SENSING UNIT MOUNTING PLATE REPLACEMENT

**NOTE: WHEN REPLACING THE MOUNTING PLATE THE SENSING UNIT BOARD IS THE ONLY ITEM THAT SHOULD BE RE-USED. REPLACE ALL OTHER ITEMS WITH THE NEW ONES FROM THE REPLACEMENT KIT.**

After removing the original unit, install the new assembly applying the Level Adjustment Screw first. Align the top hole of the adjustment nut with the top hole in the mounting plate. Install the Tension Adjustment Screw. Tighten this screw until it bottoms out. Install the sensing unit board last. Do not over tighten the Sensing unit board mounting screws. Plug the board in, make sure the control box is mounted securely and the Plexiglas cover is in place, then adjust the sensing unit.

**NOTE: IT MAY BE EASIER TO REMOVE THE CONTROL BOX FROM IT'S MOUNTING TO REPLACE THE MOUNTING PLATE.**

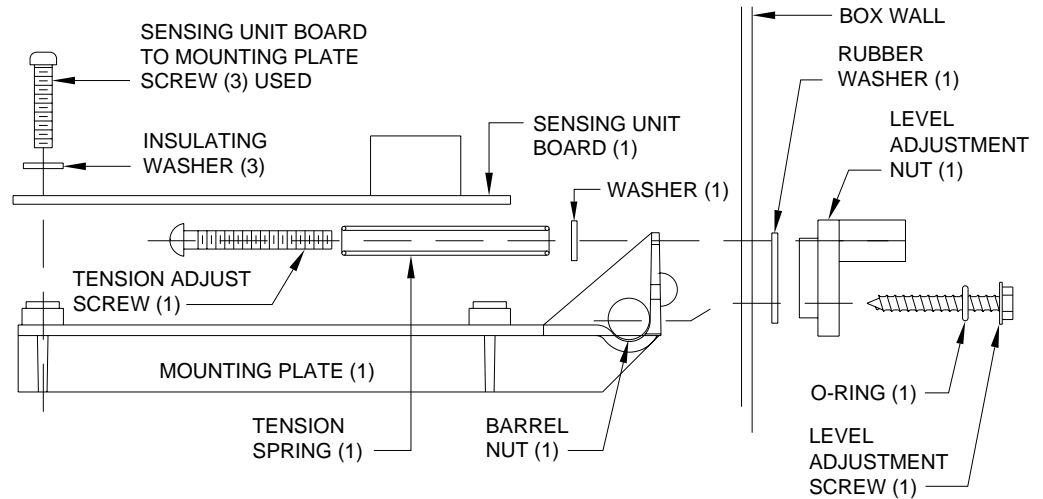

### SENSING UNIT ADJUSTMENT

Level the vehicle by placing a bubble level in the center of the freezer floor or upon whichever surface within the vehicle that is to be level. Using the Leveling System and the bubble level, ignoring the yellow LEVEL lights on the Touch Panel, level the vehicle until the bubble is centered.

When the vehicle is level according to the bubble level, if there are no yellow lights lit on the Touch Panel, the sensing unit is properly adjusted.

There are four LED's on the Sensing Unit, A,B,C and D. Refer to the drawing below. The Sensing Unit is adjusted by turning the adjustment nut to turn out LED's B and D. The adjustment screw will turn out LED's A and C. If the adjustment nut has to be turned more than 1/2 flat to turn the LED out, there may be a problem with the Sensing Unit or the mounting of the Control Box. Be careful to not turn the adjustment screw out to far or over tighten it. If two LED's are on, either adjustment may be made first.

**NOTE: If opposing LED's are lit, there is a problem with the Sensing Unit.**

**If LED (A) is lit: Turn the adjustment screw COUNTER CLOCKWISE until the LED is off.**

**If LED (C) is lit: Turn the adjustment screw CLOCKWISE until the LED is off.**

**If LED (B) is lit: Turn the adjustment nut COUNTER CLOCKWISE until the LED is off.**

**If LED (D) is lit: Turn the adjustment nut CLOCKWISE until the LED is off.**

**When all 4 LED's are off, the Sensing Unit is adjusted.**

