

# HWH CORPORATION

## HOSE SWAGING AND REPAIR INSTRUCTIONS

These instructions must be followed carefully to assure quality hose swaging and repair. Failure to follow these instructions will result in swaging failures causing leaks and unnecessary replacement of hoses or hose ends.

1. Refer to the HOSE / FITTINGS / SWAGING GUIDE sheet, number ML24976, for information which is important when making or repairing a hose. HWH uses several styles and sizes of hydraulic hose. It is important to match the correct hose end with the hose being used. Also the Die and Pusher must be matched to the hose and hose end. The ML24976 sheet contains this information.

2. The hose should be cut with a sharp hose or tubing cutter. The cut should be a flat 90 Degree cut. Hose cut at an angle may cause leaks.

3. Make sure the swaging equipment, the new hose end, and the hose are clean. Use NEVER-SEEZ on the outside of the hose end before swaging. The die and hose end will gall if NEVER-SEEZ is not used.

**IMPORTANT: Before swaging a hose end the swaging equipment should be checked. Look for nicks or dents on the die mating surfaces and where the die seats in the swaging tool. Any deformations in these areas could cause the dies to not fit together properly during the swaging procedure. Check the die for galling in the area that the hose end is pushed into. Any damaged die or swaging tool should be replaced or fixed before being used. Using damaged equipment will result in improperly swaged hose ends and leaks.**

4. Set the dies in the swaging tool and lock in place with the dogs. Feed the hose through the die.

5. The hose has to be inserted into the hose end as far as it can go. The hose should go into the hose end approximately to the part number on the hose end. It is a good idea to insert the hose before starting the actual swag and marking the hose with a piece of tape. The tape will show the hose was not pulled from the hose end as the swag was performed.

**NOTE: When repairing a hose with oil in it be careful to not point the hose down into the hose end. This could let oil fill the hose end causing a swaging problem and a leak.**

6. Run the pusher down to the hose end. Make sure the hose end is seated in the pusher. Make sure the hose end is not tilted to one side of the pusher. Turn the swaging tool handle until the pusher is turned down to contact the die set. Take care that the hose does not pull out of the hose end as the swag is started. If the hose was marked, this can be checked when the swag is complete.

**DO NOT USE AN IMPACT WRENCH TO TURN THE SWAGING TOOL.**

7. To properly tighten the hose onto a fitting, make the hose end snug (finger tight) on the fitting. Using the proper wrench, tighten the hose end 2 flats (1/3 turn) NO MORE.

**IMPORTANT: A hose that is repaired due to a hose end leak may have residual oil trapped between the inner core and the outer covering. The outer hose cover has weep holes in it. Any residual oil can seep from these weep holes as the hose is pressurized. This seepage may continue for some time after the repair. It is important to wipe the hose several times and inform the customer of this possibility. THIS IS NOT A LEAKY HOSE END. However, if the hose continuously drips fluid a problem is indicated.**

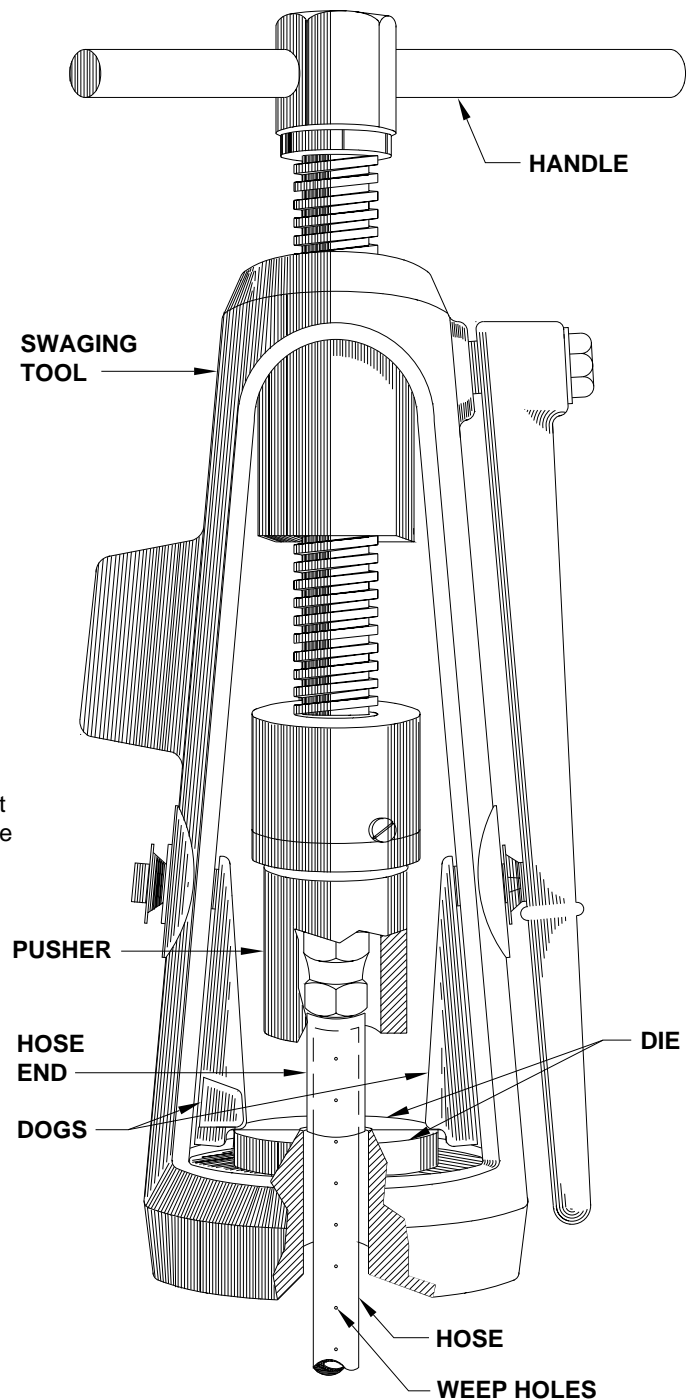

MI95.400F  
05MAY03