



(On I-80, Exit 267 South) 2096 Moscow Road, Moscow, Iowa 52760

Phone: (800)321-3494 or (563)724-3396 Fax: (563)724-3408 Internet: www.hwhcorp.com

PRODUCT/SERVICE BULLETIN

ISSUE DATE: February 15, 1993

TO: All O.E.M. Manufacturers and Installers

FROM: HWH Corporation

RE: Adjustment for 610 Jack Pressure Switch

ADJUSTMENT FOR 610 JACK PRESSURE SWITCH

The 610 System utilizes a pressure switch on each jack to achieve the proper stabilizing pressure. Each jack should lift the coach 1/2" to 1" when stabilizing the coach. The coach should be leveled in several different positions so that each jack can be checked. These pressure switches are adjustable. Loosen the locking nut and turn the pressure adjust body clockwise to increase pressure, turn counterclockwise to decrease pressure.

NOTE: Only turn adjuster 1/2 turn at a time and recheck for stabilization.

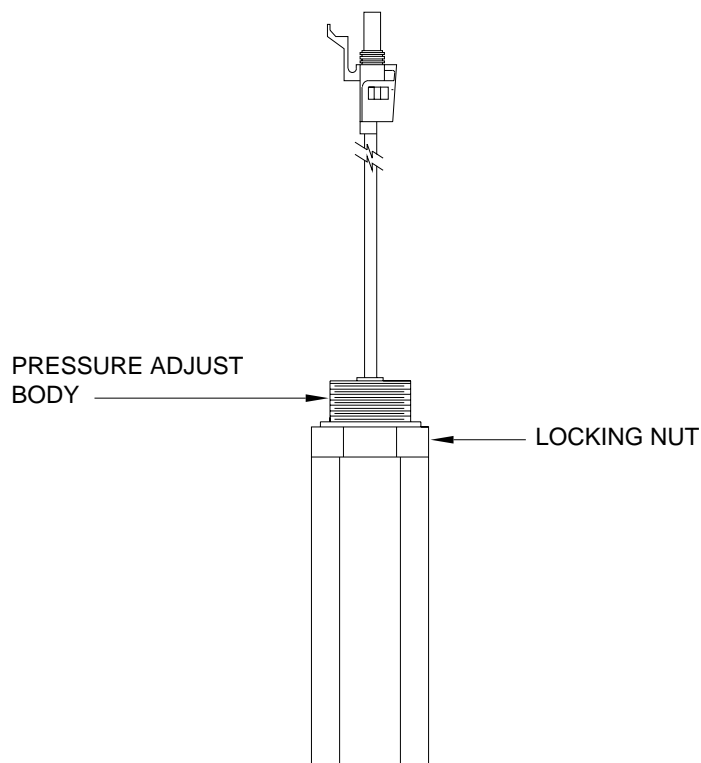

If the jacks or an individual jack comes down but does not touch the ground, do not adjust the level sensor. Adjust the pressure switch(es) as described above.

Please contact HWH Corporation at (800) 321-3494 for technical advice or assistance.

MI95.44
30MAR01