

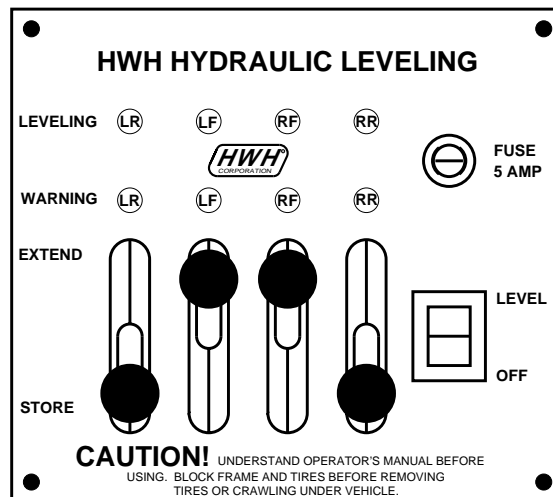

OPERATOR'S MANUAL

HWH LEVER-CONTROLLED 110 SERIES LEVELING SYSTEM

FEATURING:
Four Lever Control
Hydraulic Leveling
Straight-Acting Jacks



INTEGRATED CONTROLS

HWH CORPORATION
(On I-80, Exit 267 South)
2096 Moscow Road | Moscow, Iowa 52760
Ph: 800/321-3494 (or) 563/724-3396 | Fax: 563/724-3408
www.hwh.com

AP10038 - U.S.
AP10295 - Europe

ML10038/MP05.1000/LH-S
18JUN02

OPERATOR'S MANUAL

CAUTION !

READ THE ENTIRE OPERATOR'S MANUAL BEFORE OPERATING.

BLOCK FRAME AND TIRES SECURELY BEFORE CRAWLING UNDER VEHICLE. DO NOT USE LEVELING JACKS OR AIR SUSPENSION TO SUPPORT VEHICLE WHILE UNDER VEHICLE OR CHANGING TIRES. VEHICLE MAY DROP AND/OR MOVE FORWARD OR BACKWARD WITHOUT WARNING CAUSING INJURY OR DEATH.

KEEP ALL PEOPLE CLEAR OF VEHICLE WHILE LEVELING SYSTEM AND ROOM EXTENSION ARE BEING OPERATED.

THE JACKS MAY ABRUPTLY SWING UP WHEN THE FOOT CLEARS THE GROUND OR WHEN JACK REACHES FULL EXTENSION.

NEVER PLACE HANDS OR OTHER PARTS OF THE BODY NEAR HYDRAULIC LEAKS. OIL MAY PENETRATE SKIN CAUSING INJURY OR DEATH.

WEAR SAFETY GLASSES WHEN INSPECTING OR SERVICING THE SYSTEM TO PROTECT EYES FROM DIRT, METAL CHIPS, OIL LEAKS, ETC. FOLLOW ALL OTHER APPLICABLE SHOP SAFETY PRACTICES.

IF THIS VEHICLE IS EQUIPPED WITH KICK-DOWN STYLE JACKS, DO NOT OVER EXTEND THE REAR JACKS. IF THE WEIGHT OF THE VEHICLE IS REMOVED FROM ONE OR BOTH REAR WHEELS, THE VEHICLE MAY ROLL FORWARD OR BACKWARD OFF THE JACKS.

NOTE: KEEP THE CONTROL VALVE LEVERS IN THE STORE POSITION WHEN JACKS ARE NOT IN USE.

IMPORTANT: IF VEHICLE IS EQUIPPED WITH A ROOM EXTENSION, READ ROOM EXTENSION SECTION BEFORE OPERATING LEVELING SYSTEM.

HOW TO OBTAIN WARRANTY SERVICE

THIS IS NOT TO BE INTERPRETED AS A STATEMENT OF WARRANTY

HWH CORPORATION strives to maintain the highest level of customer satisfaction. Therefore, if you discover a defect or problem, please do the following:

FIRST: Notify the dealership where you purchased the vehicle or had the leveling system installed. Dealership management people are in the best position to resolve the problem quickly. If the dealer has difficulty solving the problem, he should immediately contact the Customer Service Department, at HWH CORPORATION.

SECOND: If your dealer cannot or will not solve the problem, notify the Customer Service Department:
HWH CORPORATION 2096 Moscow Rd. Moscow IA. 52760
(563) 724-3396 OR (800) 321-3494. Give your name and address, coach manufacturer and model year, date the coach was purchased, or the date of system installation,

description of the problem, and where you can be reached during business hours (8:00 a.m. till 5:00 p.m. c.s.t.). HWH CORPORATION personnel will contact you to determine whether or not your claim is valid. If it is, HWH CORPORATION will authorize repair or replacement of the defective part, either by appointment at the factory or by the authorization of an independent service facility, to be determined by HWH CORPORATION. All warranty repairs must be performed by an independent service facility authorized by HWH CORPORATION, or at the HWH CORPORATION factory, unless prior written approval has been obtained from proper HWH CORPORATION personnel.

CONTROL IDENTIFICATION

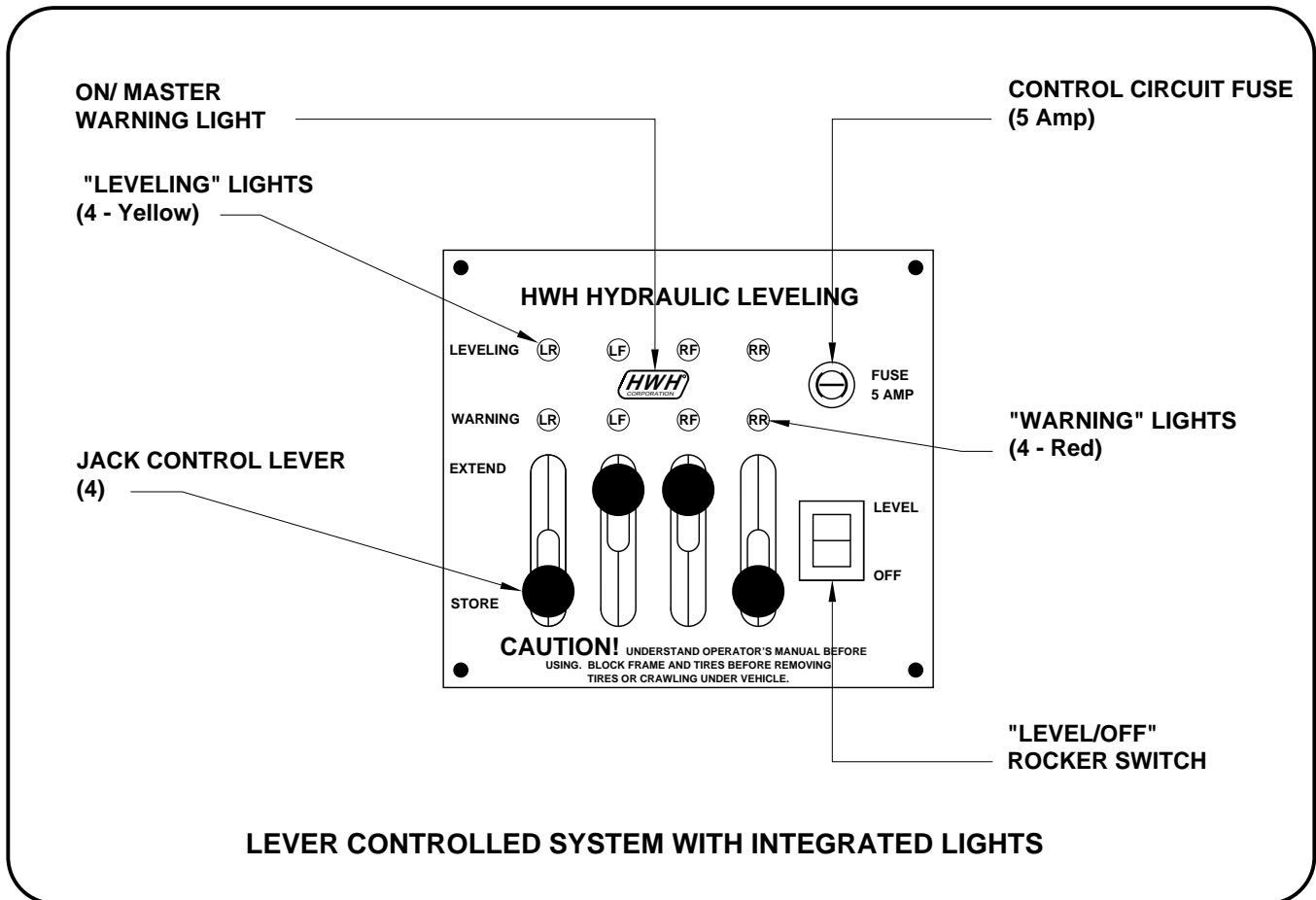

CONTROL FUNCTIONS

CONTROLS

"LEVEL/OFF" ROCKER SWITCH: This switch controls power to the "LEVELING" and "WARNING" lights, and the power unit. It does not control power to the master "JACKS DOWN" warning light, the master WARNING light on the panel, or the buzzer.

CONTROL CIRCUIT FUSE: This fuse protects the panel.

JACK CONTROL LEVER: These levers control individual jacks. Push a lever toward "EXTEND" to extend a jack or "STORE" to retract a jack.

WARNING BUZZER: A buzzer will sound if any jack is extended 2 inches or more and the ignition switch is in the "ON" position.

INDICATOR LIGHTS

ON/MASTER WARNING LIGHT: This light will be on if the ignition is in the "ON" or "ACC" position and the "LEVEL/OFF" rocker switch is in the "LEVEL" position or if one of the jacks are extended 2 inches or more and the ignition switch is in the "ON" or "ACC" position.

"WARNING" LIGHTS: A red "WARNING" light will be on whenever the corresponding jack is extended 2 inches or more, provided the ignition is in the "ON" or "ACC" position and the system is on. Some coaches are equipped with a dash mounted master "JACKS DOWN" light which will be on when one or more jacks are extended 2 inches or more, provided the ignition switch is in the "ON" position.

"LEVELING" LIGHTS: A lit yellow "LEVELING" light indicates the corresponding corner is low. Extend the appropriate jack(s) to put out the yellow light(s). One or two yellow lights can be on at the same time. The vehicle is level when all yellow lights are out.

OPERATION PROCEDURES

SITE SELECTION

Park with the front of the vehicle facing downhill if possible. If parking on soft ground or asphalt paving, wood blocks or pads should be placed under the jacks.

ROOM EXTENSION PROCEDURES

IMPORTANT: If the vehicle is equipped with a room extension read this section carefully.

If the vehicle is equipped with kick-down jacks, the wheels MUST be blocked securely. Do NOT operate any room extension until the leveling and stabilizing procedure is complete. Do NOT retract the leveling system until all room extensions are retracted. NEVER operate the leveling system when any room extensions are extended.

Refer to the vehicle owner's manual for proper operation of room extensions.

IMPORTANT: Do not use a room extension support when the vehicle is supported by the leveling system.

LEVELING PROCEDURE

1. Place gear selector in the park position apply the park brake. Block tires securely.
2. Turn the ignition switch to "ACCESSORY".
3. Push the rocker switch in jack control plate to "LEVEL".

IMPORTANT: Overheating and excessive current draw will result if control levers are partially operated toward "EXTEND" for an extended period of time.

4. A lit yellow "LEVEL" light indicates that corner of the vehicle is low. Extend jacks as needed to put out all the yellow lights. As a jack extends two inches or more, its respective red "WARNING" light will come on.

LEVELING TIPS: Two jacks maybe operated at the same time, if desired. Operation of both side jacks at the same time often provides a smoother lift while reducing stress on the vehicle and jacks. If for example, a right front and a right rear yellow

"LEVEL" light is on, operate the right rear jack or the right front and right rear jacks together. Right to left leveling is usually best accomplished using a rear jack or a front and rear jack together. If a substantial amount of leveling is required, it is often best to operate two jacks at the same time, leveling side to side first.

If the ground is too uneven the jacks may not have enough stroke to level the vehicle. The vehicle may have to be moved.

5. After the vehicle is level, the jacks not used for leveling may be extended until they touch the ground. This provides additional stability against wind and activity in the vehicle.

6. Turn off the rocker switch on the leveling system panel.

7. Turn off the ignition switch.

NOTE: The leveling system should be cycled once a month or whenever the vehicle is used, to keep the system in good operating condition.

OPERATING PROCEDURES

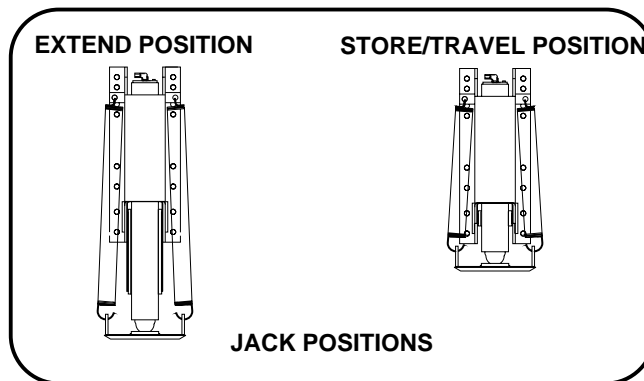

RETRACT PROCEDURES

CAUTION: MAKE SURE THAT PEOPLE AND EQUIPMENT ARE CLEAR OF THE VEHICLE.

1. Move the control levers to the "STORE" position. Retracting the two rear jacks followed by the two front jacks will provide a smooth retraction.

CAUTION: THE CONTROL LEVERS SHOULD BE KEPT IN THE "STORE" POSITION WHILE TRAVELING TO KEEP THE JACKS IN THE STORE/TRAVEL POSITION.

2. Visually check that all jacks are in the STORE/TRAVEL position. With the ignition switch in the "ON" position and the rocker switch in the "LEVEL" position, the red WARNING light, the master "JACKS DOWN" light and the buzzer will be off.

CAUTION: DO NOT MOVE THE VEHICLE WHILE THE LEVELING JACKS ARE STILL IN CONTACT WITH THE GROUND OR IN THE EXTEND POSITION. THIS VEHICLE IS EQUIPPED WITH STRAIGHT-ACTING JACKS. MOVING THE VEHICLE WITH THE LEVELING JACKS EXTENDED CAN CAUSE SEVERE DAMAGE TO THE JACKS AND/OR THE VEHICLE AND CREATE A DRIVING HAZARD. DO NOT RELY SOLELY UPON WARNING LIGHTS. IT IS THE OPERATOR'S RESPONSIBILITY TO CHECK THAT ALL JACKS ARE FULLY RETRACTED INTO THE STORE/TRAVEL POSITION.

3. Push the rocker switch on the jack control plate to "OFF". Turn the ignition off or proceed to travel.

MAINTENANCE

OIL LEVEL

It is important that the four leveling jacks and all HWH room extensions are fully retracted before checking the oil level. To check the oil supply, remove the breather cap from the top of the hydraulic reservoir. The oil level should be approximately one inch below the top of the reservoir when adequately filled.

FLUID: HWH Specialty Hydraulic Oil is recommended. In an emergency Dexron automatic transmission fluid can be used.
NOTE: Dexron automatic transmission fluid contains red dye and can cause staining should a leak occur. **DO NOT USE** brake fluid or hydraulic jack fluid. Use of these can damage seals.

ELECTRICAL SYSTEM

The batteries should be in good condition and fully charged. All electrical connections, especially ground connections, should be clean, tight, free from corrosion and protected

from corrosion. Weak batteries can cause erratic operation. Battery cable terminals, battery posts and connections should be kept clean and protected from corrosion.

UNUSUAL CONDITIONS

If driving conditions are unusually muddy, the jacks may become caked or clogged with mud. This condition may hamper the proper operation of the leveling system. This problem may be prevented or remedied by cleaning off each leveling jack if they become excessively muddy.

Do not move the vehicle while the leveling jacks are still in contact with the ground. Place the system in the store mode and then visually check to see if the leveling jacks have returned to the STORE/TRAVEL position.

In wet or icy weather leveling jacks may become encrusted with ice. This may cause the leveling system to function improperly. To eliminate this problem, periodically check the leveling jacks and break loose any ice which may be causing improper operation.

NOTE: All major components of the system can be replaced with rebuilt parts or can be sent to HWH CORPORATION to be rebuilt, when the system is out of warranty.

LEVEL SENSING UNIT ADJUSTMENT

Level the vehicle by placing a circular bubble level in the center of the freezer floor or location within the vehicle that is to be level. With the vehicle level, adjust the sensing unit until all yellow lights are off. This is done by drawing up the corresponding screw if the sensing unit is mounted below the surface as shown or backing out the corresponding screw if the sensing unit is mounted above the surface. Bump the sensing unit to see that it is settled tight against all three screw heads and still indicates that the unit is level.

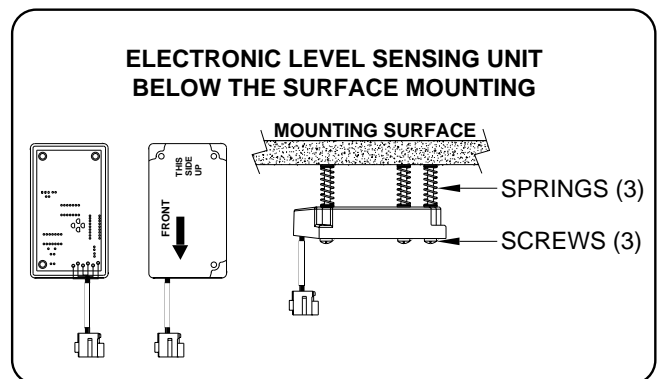
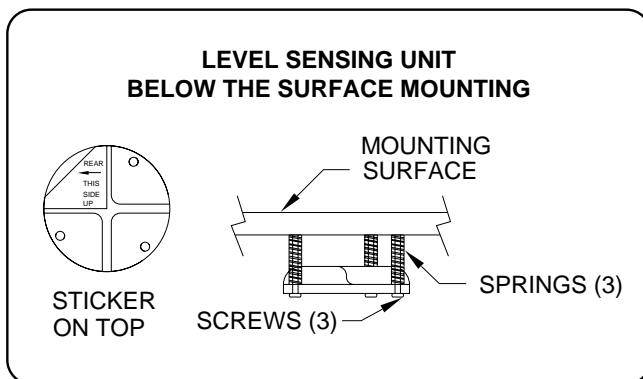

MAINTENANCE

HYDRAULIC CONTROL VALVE ADJUSTMENT

Two parts of the control valve are possible to adjust. The proper adjustments for these parts are made at the factory, so readjustments will rarely be necessary.

NOTE: These valve adjustments should only be made on a non-warranty basis. If the valve needs to be repaired or adjusted under warranty, the complete valve unit should be replaced, but not the light panel.

The following procedures are recommended to adjust them if the need arises.

1. ADJUSTMENT OF THE DETENT PLATE: Adjustment of the detent plate is necessary if the detent plate fails to hold the control levers in the retract position, or if the plunger is not depressed sufficiently by the valve handle in the retract position.

To adjust the detent plate, loosen the nuts which hold the plastic valve box and the detent plate to the valve assembly. The proper adjustment can be made by moving the detent plate up or down to a point where the valve handle is resting solidly on the

detent in the retract position, yet holding the plunger down to its full extent or no less than 1/16" of this extension.

2. ADJUSTING THE MICRO SWITCH: The micro switch will need adjusting if the activating rod does not fall directly upon the nipple of the micro switch.

The adjustment must be made after disassembling a portion of the control valve. First, remove the plastic valve box and the detent plate. Next, remove the snap rings on the pivot rod, and carefully slide off the valve handles spacers and spring, notice where each part must go during reassembly.

The micro switch is adjusted by loosening the small hex nuts which hold the micro switch to the pivot plate, and then making the proper adjustment.

NOTE: Sometimes the activating rod can be bent to position the micro switch correctly.

Finally, reassemble the control valve, remembering to properly adjust the detent plate as it is replaced.

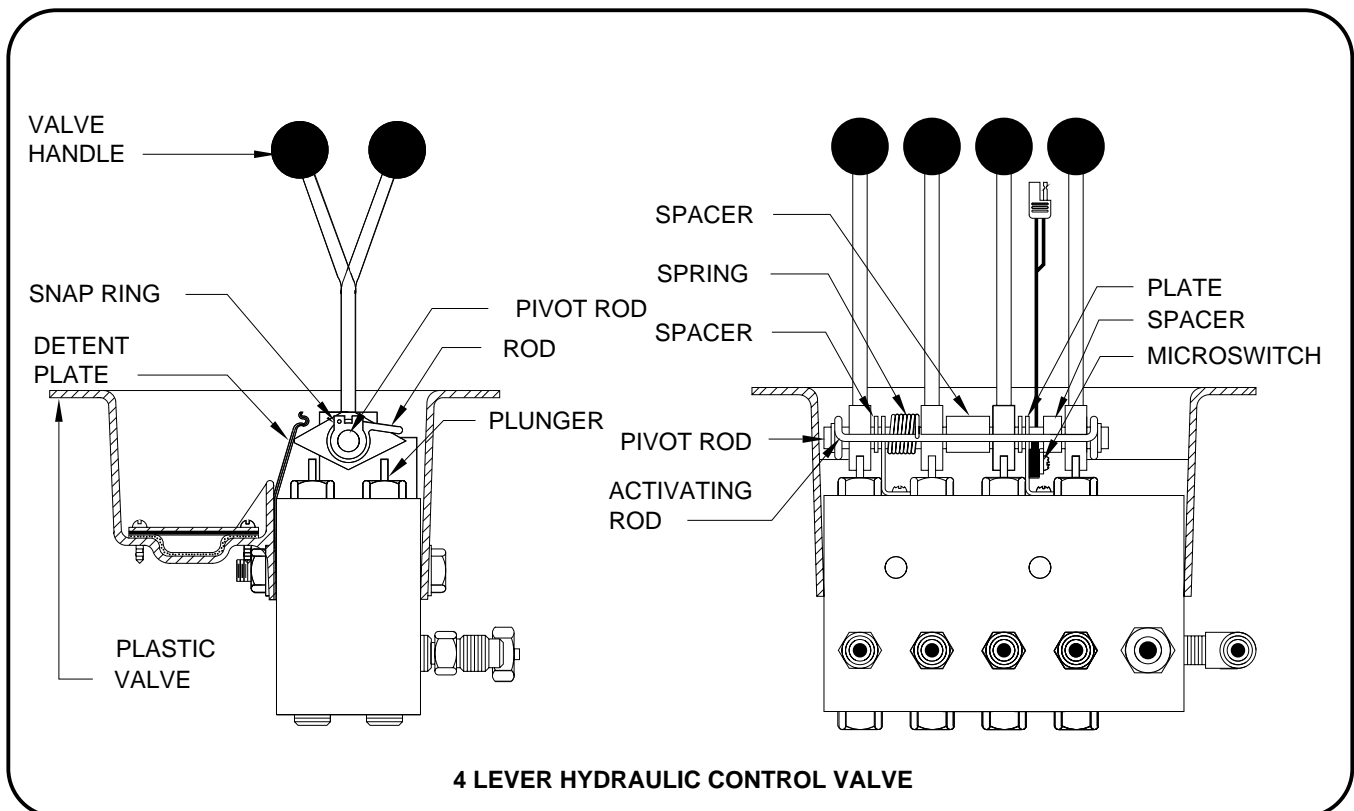

TROUBLE SHOOTING LEVELING SYSTEM

The following is a list of troubles, and possible solutions which might occur to the leveling system.

NOTE: Only qualified technicians should install or repair leveling systems on vehicles. A knowledge of hydraulics, welding, the vehicle's suspension and electrical system, as well as an understanding of the leveling system's hydraulics and electronics is required.

1. JACK RETRACTS AFTER COACH IS LEVEL.

- A. Hose or jack has external leak.
- B. Fluid is leaking back to reservoir through control valve.

2. LEVELING JACKS WILL NOT RETRACT COMPLETELY.

- A. Jack clogged with mud or ice.
- B. Main rod bent or scored.
- C. Valve plunger not completely depressed by valve handle.
- D. Springs weak or broken.
- E. Hydraulic line pinched.

3. IGNITION SWITCH ON, BUT NO POWER TO PUMP AND/OR LIGHT.

- A. Bad micro switch.
- B. Pump relay not functioning.
- C. 12 volts from main power source not present.
- D. Bad rocker switch.
- E. Faulty wire or electrical connection.
- F. Pump not grounded.
- G. Blown fuse.

4. LEVELING LIGHTS (YELLOW) NOT FUNCTIONING PROPERLY.

- A. Yellow lights will not go out when vehicle is level: adjust sensing unit.
- B. More than two yellow lights on: replace sensing unit.
- C. Check PC board.

5. WARNING LIGHTS (RED) NOT FUNCTIONING PROPERLY.

- A. Light will not come on: check for broken wire at warning switch on the jack.
- B. Lights will not go out: bad warning switch or wires are shorted to ground.
- C. Check PC board.

6. HYDRAULIC PUMP ACTIVATES, BUT THE JACKS WILL NOT EXTEND.

- A. Control valve not in the full "EXTEND" position.
- B. Oil supply low in reservoir.
- C. Pump is not developing pressure.
- D. Broken hydraulic line.

7. HYDRAULIC PUMP ACTIVATES WITHOUT USE OF CONTROL VALVE HANDLES.

- A. Micro switch out of adjustment.
- D. Broken spring on pivot rod.
- C. Pump relay stuck.
- D. Short in PC board.

110 SYSTEM
HYDRAULIC LINE CONNECTION DIAGRAM
FOUR LEVER INTEGRATED CONTROL

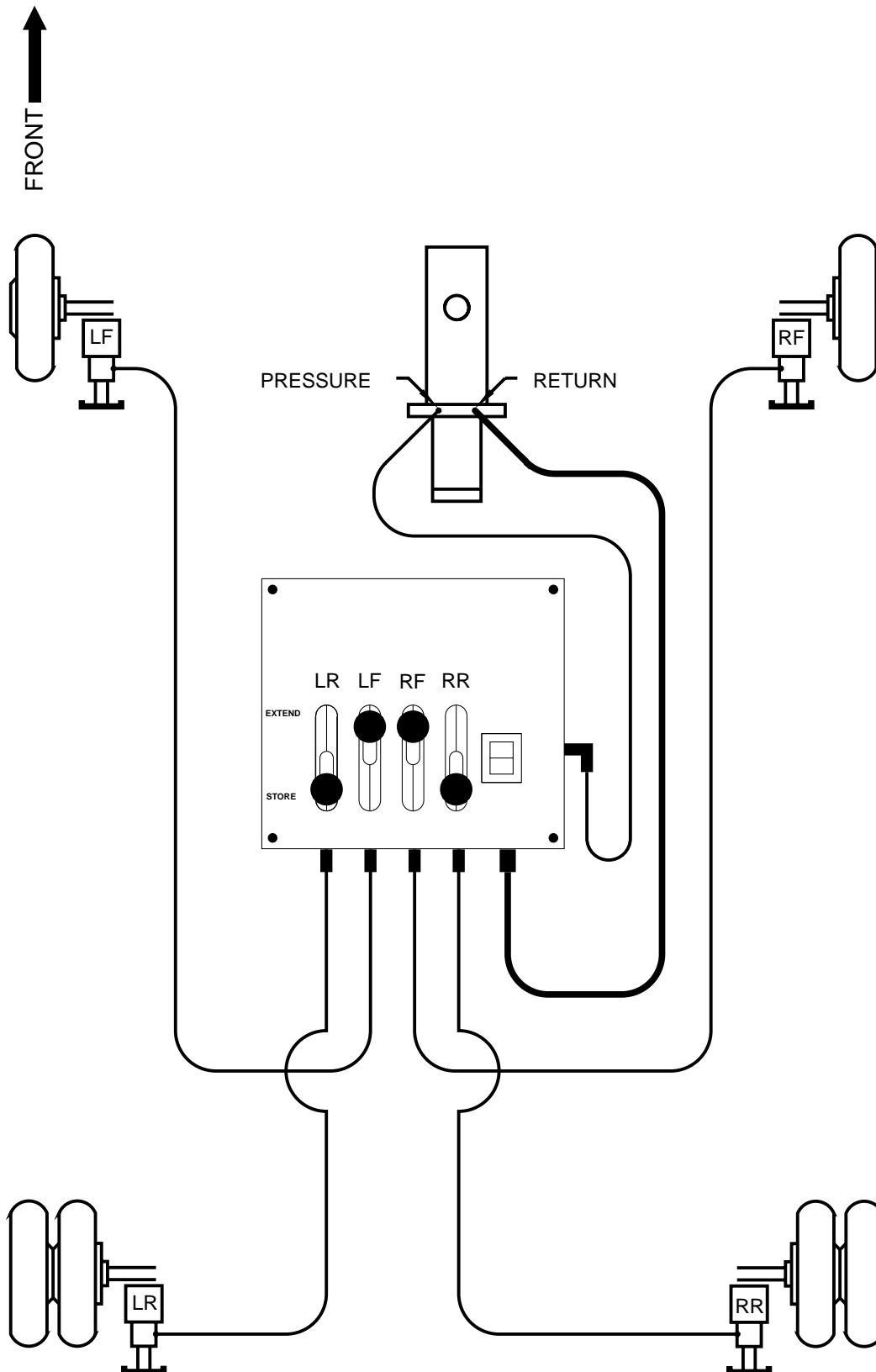

ELECTRICAL CONNECTION DIAGRAM 110 SERIES LEVELING SYSTEM FOUR LEVER INTEGRATED CONTROL

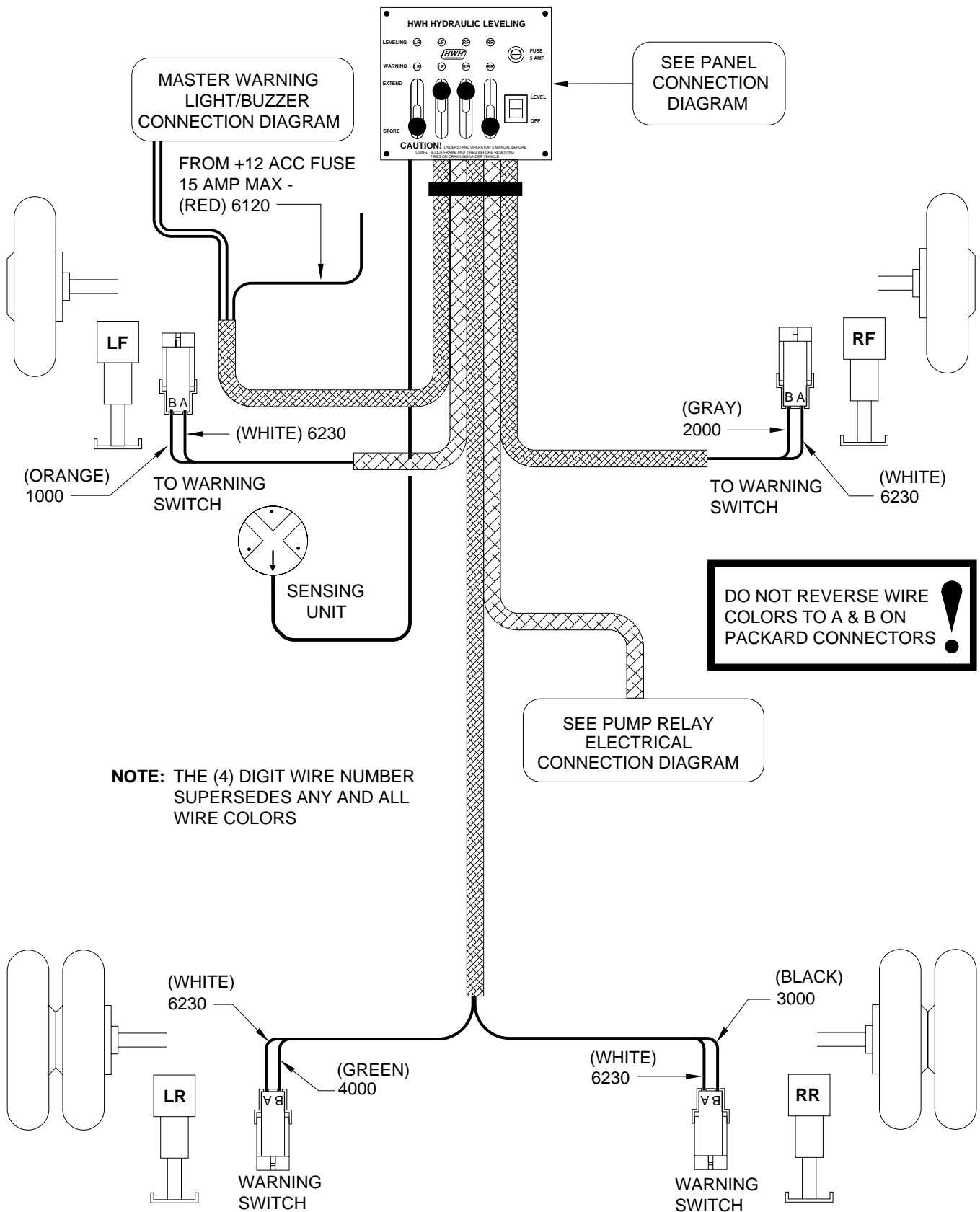

ELECTRICAL CONNECTION DIAGRAM 110 SERIES LEVELING SYSTEM FOUR LEVER INTEGRATED CONTROL

PUMP RELAY CONNECTION DIAGRAM

PUMP MUST BE MOUNTED SOLIDLY TO FRAME. SOME PUMPS HAVE A GROUND CABLE THAT IS TO BE ATTACHED TO THE GROUND STUD.

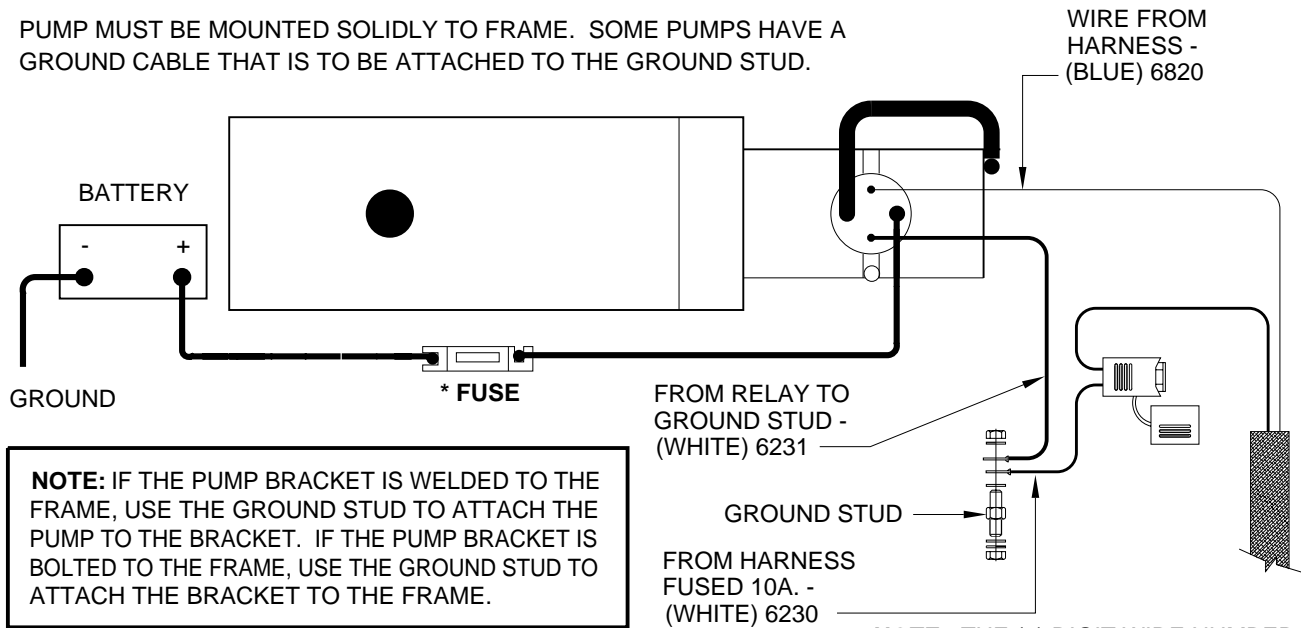

NOTE: IF THE PUMP BRACKET IS WELDED TO THE FRAME, USE THE GROUND STUD TO ATTACH THE PUMP TO THE BRACKET. IF THE PUMP BRACKET IS BOLTED TO THE FRAME, USE THE GROUND STUD TO ATTACH THE BRACKET TO THE FRAME.

NOTE: THE (4) DIGIT WIRE NUMBER SUPERSEDES ANY AND ALL WIRE COLORS

* FUSE MAY BE REQUIRED - CHECK APPLICABLE CODE

PANEL CONNECTION DIAGRAM

- 9-PIN MTA HARNESS**
- NOT USED
 - RR - (BLACK) 3000
 - RF - (GRAY) 2000
 - LF - (ORANGE) 1000
 - LR - (GREEN) 4000
 - +WARN - (PURPLE) 6121
 - WARN - (BROWN) 7699
 - PUMP - (BLUE) 6820
 - GROUND - (WHITE) 6230

- 5-PIN MTA SENSING UNIT**
- RR - RED
 - RF - GREEN
 - LF - BLACK
 - LR - YELLOW
 - COM. - WHITE

NOTE: THE (4) DIGIT WIRE NUMBER SUPERSEDES ANY AND ALL WIRE COLORS

TO +12 "ACCESSORY" POWER FUSED 15A. MAX - (RED) 6120

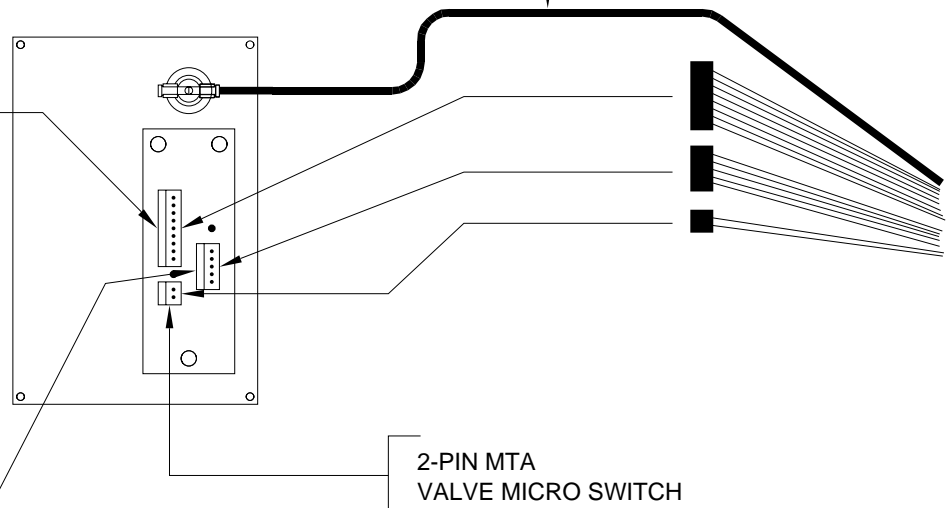

ELECTRICAL SCHEMATIC
100/110 SERIES LEVELING SYSTEM
LIGHT PANEL (INTEGRATED OR REMOTE 4-LEVER) SYSTEM
STRAIGHT-ACTING JACKS WITHOUT AIR DUMP FEATURE

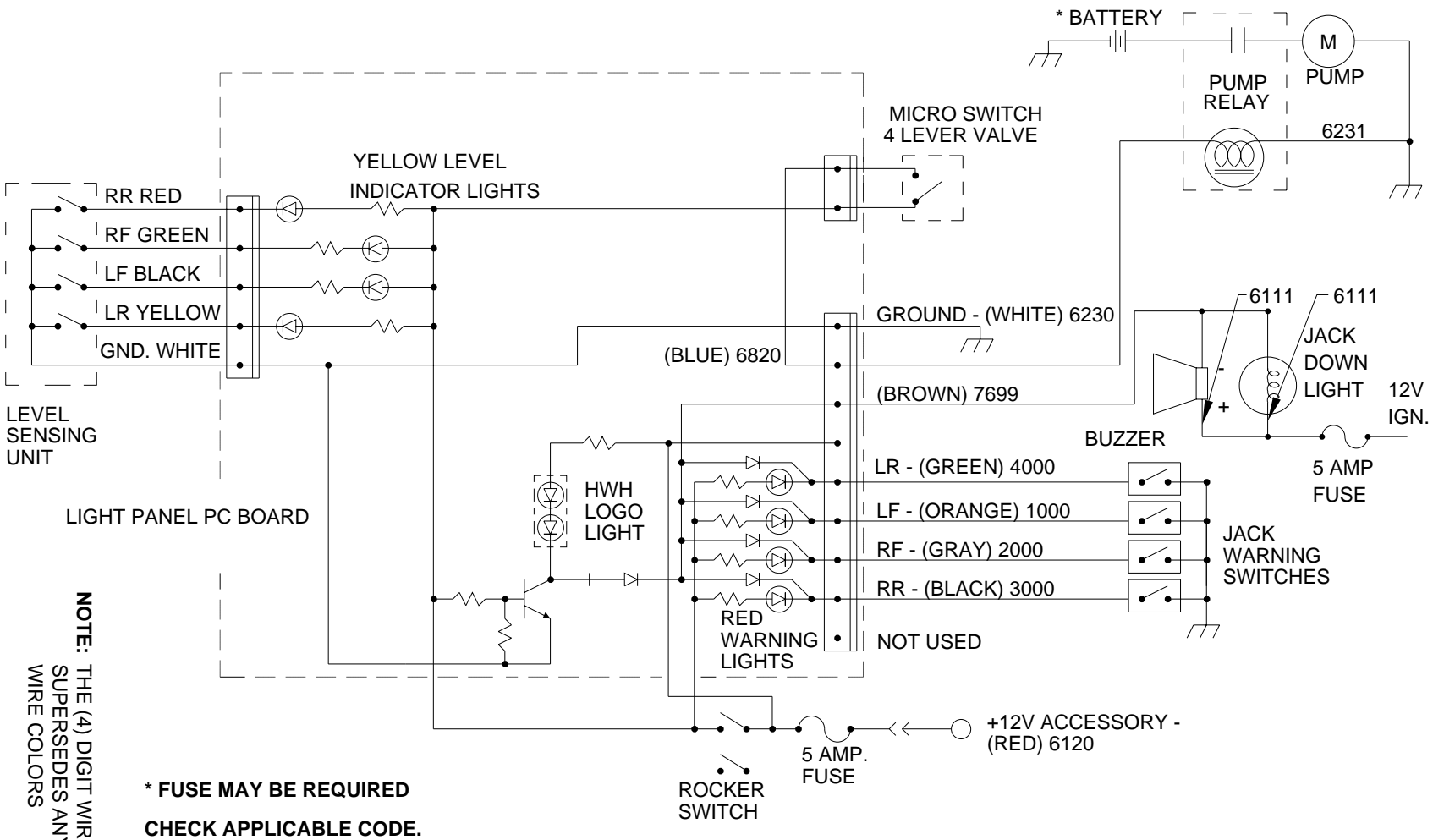

NOTE: THE (4) DIGIT WIRE NUMBER
 SUPERSEDES ANY AND ALL
 WIRE COLORS

MASTER LIGHT/BUZZER CONNECTION DIAGRAM MANUAL LEVELING SYSTEMS

A MASTER WARNING INDICATOR SHOULD ALWAYS BE USED. WHEN THE LEVELING SYSTEM HAS STRAIGHT-ACTING JACKS A WARNING BUZZER MUST BE USED.

WHEN ONLY A RED MASTER WARNING LIGHT IS USED THE +12 POWER FOR THE LIGHT COMES THROUGH THE CONTROL PANEL. (SEE FIGURE 1 BELOW.) WHEN BOTH A RED LIGHT AND WARNING BUZZER ARE USED THE +12 POWER FOR BOTH INDICATORS IS SUPPLIED BY THE IGNITION SWITCH. THE POWER MUST COME FROM THE "ON" SIDE OF THE IGNITION SWITCH, NOT THE "ACC" SIDE. (SEE FIGURE 2 BELOW)

NOTE: BY SUPPLYING IGNITION POWER TO THE WARNING BUZZER AND LIGHT, AND "ACC" POWER TO THE CONTROL PANEL, THE SYSTEM MAY BE OPERATED IN ACCESSORY WITHOUT THE BUZZER SOUNDING. THE NEGATIVE SIGNAL FOR THE WARNING INDICATORS MUST ALWAYS COME FROM THE CONTROL PANEL.

CAUTION: THE PURPLE WIRE IN THE MASTER WARNING LIGHT HARNESS IS HOT WHENEVER THE IGNITION IS "ON" OR IN "ACC". THE PURPLE WIRE MUST BE REMOVED FROM THE HARNESS WHEN USING DIRECT IGNITION VOLTAGE FOR THE MASTER WARNING INDICATORS.

NOTE: THE (4) DIGIT WIRE NUMBER SUPERSEDES ANY AND ALL WIRE COLORS.

