



REPAIR MANUAL
HWH SPACEMAKER
ROOM EXTENSION SYSTEM
310 SERIES HYDRAULIC LEVELING SYSTEM
FOR MOTORIZED VEHICLES

FEATURING:
DUAL CYLINDER "RAIL" ROOM EXTENSION
DUAL CYLINDER "VERTICAL ARM" ROOM EXTENSION
(WITH SYNCHRONIZING CYLINDER)

HWH CORPORATION
(ON I-80, EXIT 267 SOUTH)
2096 MOSCOW ROAD
MOSCOW, IOWA 52760
(800) 321-3494 / (563) 724-3396
INTERNET: <http://www.hwhcorp.com>

ML21956/MI91.0017
07MAR01

SECTION 1

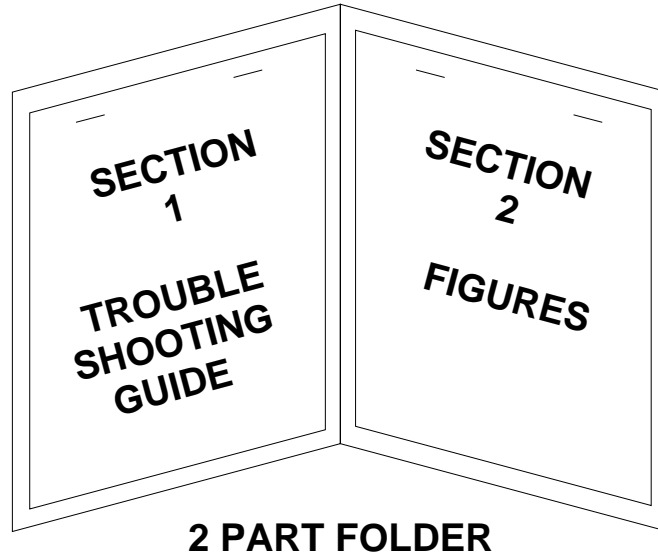

HOW TO USE MANUAL

NOTE: This manual will work for systems with single cylinder room extensions also. The only difference is the exclusion of synchronizing cylinder problems.

This manual is written in two sections. Section 1 is the Trouble Shooting Guide. Section 2 is the figures. Begin diagnosis of the system with Section 1, the Trouble Shooting Guide. The Trouble Shooting Guide is broken into 3 columns, Problem, Solutions and Figures. Under Problems, find the symptom you have encountered. The testing and repair for that problem is in the Solution (center) column. Diagrams for a particular Problem and Solution are in the Figures (right hand) column. This column will direct you to the proper figure in Section 2, Figures, for a more detailed view.

Before beginning your repair, it is IMPORTANT to read the CAUTIONS and NOTES AND CHECKS in the first section, TROUBLE SHOOTING GUIDE. In many cases this will save time and mistakes when trouble shooting a system.

This Repair Manual is offered as a guide only. It is impossible to anticipate every problem or combination of problems. For any problems encountered that are not addressed in this manual, contact HWH Corporation for assistance. (800-321-3494)

The room should be fully retracted before Trouble Shooting the system. If the room will not retract, use the manual retract procedure on pages MP35.9490.

Make sure all room locks and the manual retract winch are not engaged before trouble shooting the system.

PROCEED WITH TROUBLE SHOOTING GUIDE



TROUBLE SHOOTING

CAUTIONS!

BLOCK FRAME AND TIRES SECURELY BEFORE CRAWLING UNDER VEHICLE. DO NOT USE THE LEVELING JACKS OR AIR SUSPENSION TO SUPPORT VEHICLE WHILE UNDER VEHICLE OR CHANGING TIRES. VEHICLE MAY DROP AND OR MOVE FORWARD OR BACKWARD WITHOUT WARNING CAUSING INJURY OR DEATH.

WHEN ROUTING OR REROUTING HYDRAULIC HOSES AND WIRES, BE SURE THEY ARE NOT EXPOSED TO ENGINE EXHAUST OR ANY HIGH TEMPERATURE COMPONENTS OF THE VEHICLE.

NEVER PLACE HAND OR OTHER PARTS OF THE BODY NEAR HYDRAULIC LEAKS. OIL MAY CUT AND PENETRATE THE SKIN CAUSING INJURY OR DEATH.

SAFETY GLASSES ARE TO BE WORN TO PROTECT EYES FROM DIRT, METAL CHIPS, OIL LEAKS, ETC. FOLLOW ALL OTHER SHOP SAFETY PRACTICES.

NOTES AND CHECKS

Read and check before proceeding with Trouble Shooting Steps.

NOTE: HWH CORPORATION ASSUMES NO LIABILITY FOR DAMAGES OR INJURIES RESULTING FROM THE INSTALLATION OR REPAIR OF THIS PRODUCT.

1. The leveling system must work correctly or the room extension will not function properly. If the leveling system is not working correctly, make the necessary repairs before continuing.

2. The following conditions must be met for the room extension to operate. The ignition must be in the "ACC" position and the park brake must be set. A red Jacks Down Warning light on the HWH Panel must be on.

3. If the room extension cannot be retracted, see Figures page MP35.9490 for temporary measures. Make sure the manual retract valves are closed before trouble shooting.

If the room will not retract using the manual winch, there may be a problem with a room cylinder or the sync. cyl. DO NOT use alternate devices such as a power winch to retract the room. Contact HWH Customer services (1-800-321-3494) for assistance.

IMPORTANT : The room extension will not operate unless a jack is extended enough to turn a Jacks Down Warning light on, but the vehicle should NOT be supported by the leveling jacks when working on the room extension.

4. Check that the oil reservoir is full with the room and the leveling system in the fully retracted position.

5. Batteries should read 12.7 volts. Batteries must be in good condition with no weak cells. The system will draw up to 200 amps. An alternator, converter or battery charger will not supply enough power for the system to operate properly.

6. Proper ground of all components is critical. See the electrical circuit for specific grounds required. Faulty grounds, especially for the solenoid manifold or the pump assembly, may cause component damage and /or improper or erratic operation.

This manual is intended for use by experienced mechanics with knowledge of hydraulic and automotive electrical systems. People with little or no experience with HWH Room Extension systems should contact HWH technical service (800-321-3494) before beginning. Special attention should be given to all cautions, wiring, and hydraulic diagrams.

Tightening of hose ends: If tightening a new hose end, make the hose end snug (finger tight) on the fitting, then tighten the hose end 1/3 turn (2 FLATS). If tightening an existing hose end, tighten the hose end to snug plus 1/4 turn (1 FLAT).

Suggested tools for trouble shooting the HWH room extension systems:

JUMPER WIRES(UP TO 10 GAUGE)
PRESSURE GAUGE(3500 PSI MIN.)
MULTI-METER
12 VOLT TEST LIGHT

PROCEED WITH THE TROUBLE SHOOTING STEPS ON THE FOLLOWING PAGE



TROUBLE SHOOTING

The following is a list of possible problems and solutions which might occur to room extensions. Only qualified technicians should install or repair room extension systems. An understanding of the operation of the room extension hydraulic and electrical components is required.

The following conditions must be met for the room extension to operate. The ignition must be in the "ACC" position. The park brake must be set. A red "Jack Down Warning Light" on the HWH panel must be on. (A jack must be extended approximately two inches.) The key switch on the room operator's panel must be on.

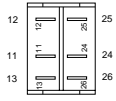
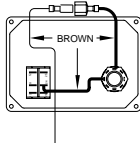
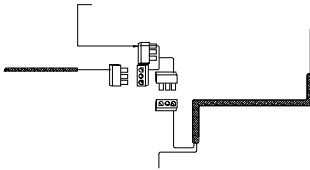
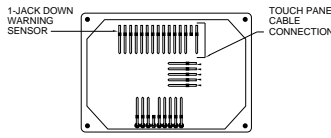
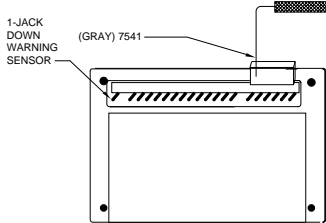
PROBLEM	SOLUTION	FIGURES
<p>Part 1 The pump will not run when the room extension switch is pushed toward EXTEND and / or RETRACT.</p> <p>Remember, a red WARNING light on the leveling system touch panel must be on for the pump to run.</p>	<p>Check for +12 at Terminal 24 of the room control switch. Refer to MP85.3038.</p> <p>Power is not present on Terminal 24. Check for power on the (BROWN) 6120 wire from the room extension pump control harness. If power is present, the key switch is bad, replace the operator's panel. If power is not present on the (BROWN) 6120 wire at the operator's panel, refer to MP85.3208. Check the connections and the room extension power adapter. If the connections are OK and there is +12 power at the power adapter, the problem is with the (BROWN) 6120 wire in the room extension pump control harness.</p> <p>Power is present on Terminal 24. Check Terminals 25 and 26 of the room control switch while pushing the switch to extend and retract. If power is not present while pushing the switch, replace the switch. If power is present, check for +12 power on the (GRAY) 7541 wire from the room extension pump control harness at the control box. If power is not present, the (GRAY) 7541 wire is the problem. Refer to MP85.3028.</p> <p>Remember, the leveling system must operate properly before testing the room extension system.</p> <p>Power is present on the (GRAY) 7541 wire at the control box. Pin 1, JACK DOWN WARNING SENSOR, of the touch panel cable input (MP85.3028) should have a ground present if a red Jack Down Warning Light is on. If Pin 1 at the control box has a ground, replace the control box. If Pin 1, (MP85.3028) at the control box does not have a ground, check Pin 1, (MP85.3007), touch panel cable connection. If Pin 1 at the touch panel has a ground, the problem is the touch panel cable. Check that the wires at both ends are securely in the connectors. If there is no ground at Pin 1 of the touch panel, replace the touch panel.</p>	<div style="text-align: center;">  </div> <p style="text-align: center;">REFER TO MP85.3038</p> <div style="text-align: center;">  </div> <p style="text-align: center;">REFER TO MP85.3038</p> <div style="text-align: center;">  </div> <p style="text-align: center;">REFER TO MP85.3028</p> <div style="text-align: center;">  </div> <p style="text-align: center;">REFER TO MP85.3007</p> <div style="text-align: center;">  </div> <p style="text-align: center;">REFER TO MP85.3028</p>

TROUBLE SHOOTING

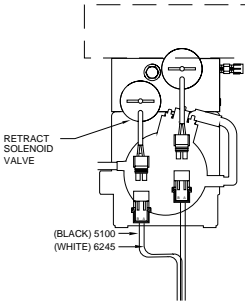
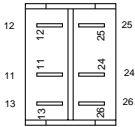
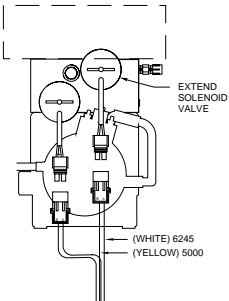
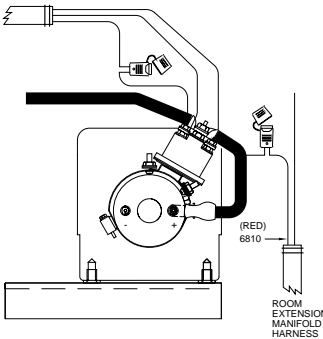
PROBLEM	SOLUTION	FIGURES
<p>Part 2 The pump runs but the room will not extend.</p> <p>a. The pump runs under no load.</p>	<p>The retract valve is open. Make sure the solenoid valve "T" handle is closed. Check for +12 power on the (BLACK) 5100 wire at the manifold. If power is not present, replace the retract valve.</p> <p>If the retract valve is open, the leveling system will not work properly. If the retract valve is OK, the problem may be the shuttle valve or the pump itself may be bad.</p> <p>If there is power on the (BLACK) 5100 wire, unplug the (BLACK) 5100 wire from Terminal 13 of the room control switch. Check Terminal 13 on the room control switch, while pushing the switch toward the "EXTEND" position. If there is power, replace the switch. If there is no power on Terminal 13, The (BLACK) 5100 wire in the room extension manifold harness is shorted to a +12 supply.</p>	 <p style="text-align: center;">REFER TO MP85.3038</p>  <p style="text-align: center;">REFER TO MP85.3038</p>
<p>b. The pump runs under a load.</p>	<p>The extend solenoid valve is not opening. While pushing the room control switch toward "EXTEND", check between the (YELLOW) 5000 and (WHITE) 6245 wires of the extend valve plug for +12 power. If power is present, replace the extend solenoid valve. If power is not present, check between the (YELLOW) 5000 wire and ground. If power is present, repair the (WHITE) 6245 wire in the plug.</p> <p>NOTE: Low voltage can cause solenoid valves to not open even though the pump is running.</p> <p>NOTE: The following checks and test must be performed with the room control switch being pushed and the pump must be running.</p> <p>Power is not present on the (YELLOW) 5000 and (WHITE) 6245 wires of the extend valve plug. Check the (WHITE) 6245 wire for a good ground connection. Check Pin 12 of the room control switch while pushing the switch toward extend. If power is present, fix the (YELLOW) 5000 wire in the manifold harness. If power is not present on Pin 12 check Pin 11 of the room control switch. If power is present replace the switch. If power is not present on Pin 11, check the (RED) 6810 wire in the room manifold harness for +12 power. If power is present the key switch is bad, replace the room operators panel. If power is not present on the (RED) 6810 wire, check the 15 amp fuse on the (RED) 6810 wire of the manifold harness at the pump relay. If the fuse is not blown, the problem is the (RED) 6810 wire. If the fuse is blown, unplug the extend and retract solenoid valves. Replace the fuse and retry. If the fuse blows, replace the room extension manifold harness. If the fuse does not blow, plug the extend valve in and retry. If the fuse blows, replace the extend solenoid valve. If the fuse does not blow, replace the retract solenoid valve.</p>	 <p style="text-align: center;">REFER TO MP85.3038</p>  <p style="text-align: center;">REFER TO MP85.3029</p>

TROUBLE SHOOTING

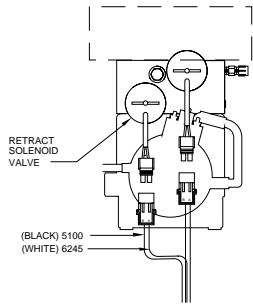
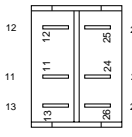
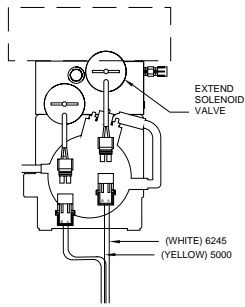
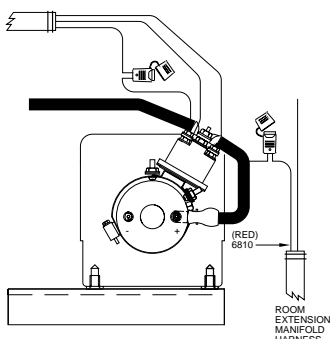
PROBLEM	SOLUTION	FIGURES
<p>Part 3 The pump runs but the room will not retract.</p> <p>a. The pump runs under no load.</p>	<p>The extend valve is open. Make sure the solenoid valve "T" handle is closed. Check for +12 power on the (YELLOW) 5000 wire at the manifold. If power is not present, replace the extend valve.</p> <p>If the extend valve is OK, the problem is the shuttle valve on the leveling system manifold or the pump is bad.</p> <p>If there is power on the (YELLOW) 5000 wire, unplug the (YELLOW) 5000 wire from Terminal 12 of the room control switch. Check Terminal 12 on the room control switch, while pushing the switch toward the "RETRACT" position. If there is power, replace the switch. If there is no power on Terminal 12, the (YELLOW) 5000 wire in the room extension manifold harness is shorted to a +12 supply.</p>	 <p style="text-align: center;">REFER TO MP85.3038</p>  <p style="text-align: center;">REFER TO MP85.3038</p>
<p>b. The pump runs under a load.</p>	<p>The retract solenoid valve is not opening. While pushing the room control switch toward "RETRACT", check between the (BLACK) 5100 and (WHITE) 6245 wires of the retract valve plug for +12 power. If power is present, replace the retract solenoid valve. If power is not present, check between the (BLACK) 5100 wire and ground. If power is present, repair the (WHITE) 6245 wire in the plug.</p> <p>NOTE: Low voltage can cause solenoid valves to not open even though the pump is running.</p> <p>NOTE: The following checks and test must be performed with the room control switch being pushed and the pump must be running.</p> <p>Power is not present on the (BLACK) 5100 and (WHITE) 6245 of the retract valve plug. Check the (WHITE) 6245 wire for a good ground connection. Check Pin 13 of the room control switch while pushing the switch toward retract. If power is present, then fix the (BLACK) 5100 wire in the manifold harness. If power is not present on Pin 13, check Pin 11 of the room control switch. If power is present replace the switch. If power is not present on Pin 11, check the (RED) 6810 wire in the room manifold harness for +12 power. If power is present the key switch is bad, replace the room operator panel. If power is not present on the (RED) 6810 wire, Check the 15 amp fuse on the (RED) 6810 wire of the manifold harness at the pump relay. If the fuse is not blown, the problem is the (RED) 6810 valve. If the fuse is blown, unplug the extend and retract solenoid valves. Replace the fuse and retry. If the fuse blows, replace the room extension manifold harness. If the fuse does not blow, plug the retract valve in and retry. If the fuse blows, replace the retract solenoid valve. If the fuse does not blow, replace the extend solenoid valve.</p>	 <p style="text-align: center;">REFER TO MP85.3038</p>  <p style="text-align: center;">REFER TO MP85.3029</p>

TROUBLE SHOOTING

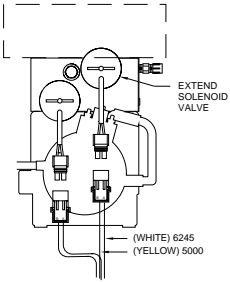
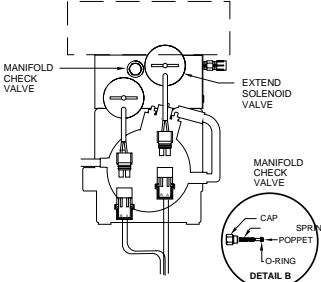
PROBLEM	SOLUTION	FIGURES
<p>Part 4 The room moves erratically from side to side (walking) as it extends or retracts.</p>	<p>Check that the pivot bracket is free to pivot. Check that the inner tubes are free of paint or undercoating. Make sure the room is not binding on the top, bottom or sides. Check that the hoses between the rod end of the room cylinders and the synchronizing cylinder are the same length and diameter. Check that the hoses connected to the cap end of the room cylinders are the same length and diameter. Check that the room extension mechanisms are not binding. Check that the awning is working properly. If this is all OK contact HWH Customer Service for assistance.</p>	<p style="text-align: center;">REFER TO MP45.3004</p> <p style="text-align: center;">REFER TO MP65.9418</p>
<p>Part 5 The ends of the room do not move at an equal distance from the vehicle.</p>	<p>Due to variations such as weight and dimensions from end to end of a room, it is possible for one end of the room to lead the other when the room is moving. If the room seals properly top to bottom and end to end, there may not be a problem. Make the same checks as in part 4 then call HWH Customer Service for assistance.</p>	
<p>Part 6 The room creeps out after being retracted.</p>	<p>The following deals with dual cylinder room extensions. There are three possibilities.</p> <ul style="list-style-type: none"> A : An extend solenoid valve is leaking. B : A room extension cylinder has an internal leak. C : The manifold check valve is leaking. D : External oil leak. <p>Note : If the room creeps out 1 inch or less the problem is most likely the check valve.</p> <p>If only one side of the room creeps out, replace the room cylinder for the side that creeps out. If both sides creep out, do the following tests. If the tests are not conclusive, replace the extend solenoid valve for the room. Check the o-rings at the end of the valve. If the o-rings are damaged, there may be a problem with the manifold.</p> <p>Retract the room completely. Remove the hydraulic line for the cap end of the cylinder at the manifold. Hold the hose end in an upright position. Press the rocker switch for that room to the "RETRACT" position.</p> <p>If fluid flows from the manifold fitting, the extend solenoid valve needs to be changed.</p> <p>If no fluid flows from either the hose end or the manifold fittings, inspect the manifold check valve. There is a spring below the cap. DO NOT lose the spring. Check for cuts on the poppet "O" ring. Check the poppet and cap for burrs. The poppet should easily slide in the cap.</p>	<p style="text-align: center;">REFER TO MP45.3004</p> <p style="text-align: center;">REFER TO MP65.9418</p> <div style="text-align: center;">  <p style="text-align: center;">REFER TO MP85.3038</p>  <p style="text-align: center;">REFER TO MP85.3038</p> </div>

TROUBLE SHOOTING

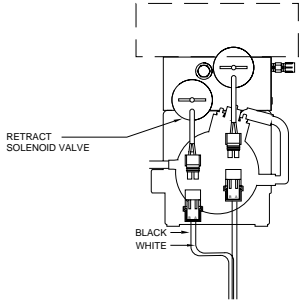
PROBLEM	SOLUTION	FIGURES
<p>Part 6 Continued</p>	<p>If the check valv is OK, or fluid flows from the hose end, the room ex- tension cylinder should be replaced.</p>	<p>DUAL CYLINDER "RAIL" REFER TO MP45.9435 AND MP45.9436</p> <p>"VERTICAL ARM" REFER TO MP45.9447 AND MP45.9448</p>
<p>Part 7 The room creeps in after being extended.</p>	<p>Check for external oil leaks. Replace the retract solenoid valve for that room extension. This is the only possibility that would cause this problem.</p>	<div style="text-align: center;">  </div> <p>REFER TO MP85.3038</p>
<p>Part 8 The room does not seal tightly when fully re- tracted or ex- tended.</p>	<p>The room stops need to be adjusted. See the adjustment section of MP45.9412 and MP45.9415.</p>	<p>DUAL CYLINDER "RAIL" REFER TO MP45.9435 AND MP45.9436</p> <p>"VERTICAL ARM" REFER TO MP45.9449 AND MP45.9450</p>

CONTROL IDENTIFICATION

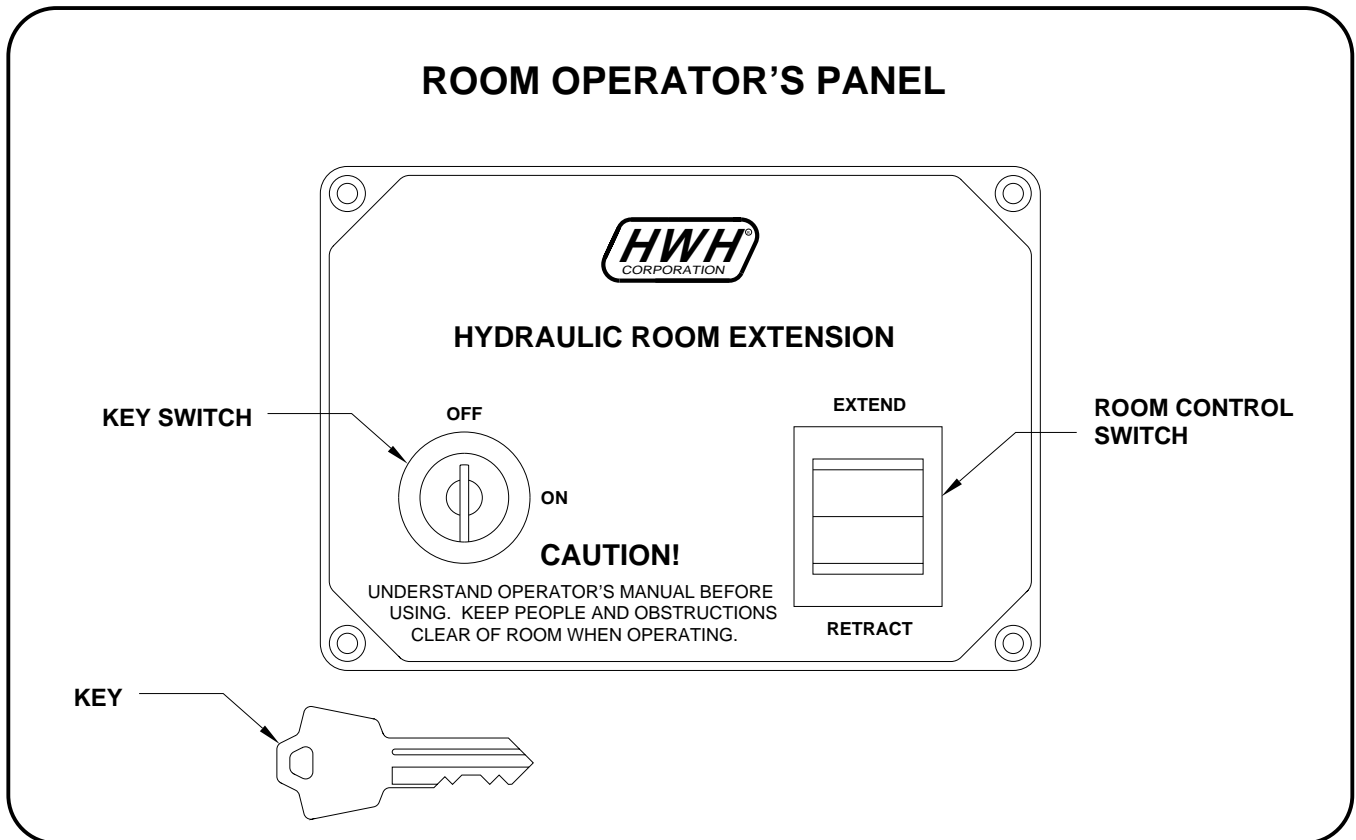

CONTROL FUNCTIONS

KEY SWITCH: The KEY SWITCH controls power to the ROOM CONTROL SWITCH. When the KEY SWITCH is in the "ON" POSITION the room can be operated, and the key cannot be removed. When the KEY SWITCH is in the "OFF" position the room cannot be operated, and the key can be removed.

ROOM CONTROL SWITCH: The ROOM CONTROL SWITCH is a two position momentary switch. Pressing the switch in the EXTEND POSITION will extend the room. Pressing the switch in the RETRACT POSITION will retract the room. Releasing the ROOM CONTROL SWITCH will halt the operation of the room.

MANUAL ROOM RETRACT PROCEDURE (WITH SOLENOID VALVES WITH VALVE RELEASE "T" HANDLES)

(USE ONLY WHEN THE ROOM WILL NOT RETRACT WITH THE ROOM CONTROL SWITCH)

OVERVIEW

The room can be retracted manually if a hydraulic or electrical failure prevents the room from being retracted using the ROOM CONTROL SWITCH. For normal retract sequence see the ROOM RETRACT PROCEDURE.

CAUTION: THE MANUAL RETRACT WINCH IS EQUIPPED FOR MANUALLY RETRACTING THE ROOM ONLY. IT IS NOT TO BE USED FOR LIFTING OR ANY OTHER APPLICATION. HIGH FORCES ARE CREATED WHEN USING A WINCH, CREATING POTENTIAL SAFETY HAZARDS. FAILURE TO FOLLOW ALL CAUTIONS AND INSTRUCTIONS MAY CAUSE FAILURE OF THE MANUAL RETRACT WINCH OR CONNECTIONS RESULTING IN DAMAGE OR PERSONAL INJURY. MAINTAIN FIRM GRIP ON THE WINCH HANDLE AT ALL TIMES. NEVER RELEASE THE HANDLE WHEN RATCHET LEVER IS IN THE OFF POSITION AND THE WINCH IS LOADED. THE WINCH HANDLE COULD SPIN VIOLENTLY AND CAUSE PERSONAL INJURY. CHECK THE WINCH AND STRAPS FOR DAMAGE OR WEAR, AND CHECK FOR PROPER RATCHET OPERATION ON EACH USE OF THE WINCH. DO NOT USE IF DAMAGED OR WORN.

1. Retract jacks following the LEVELING SYSTEM RETRACT PROCEDURE.

NOTE : When manually retracting the room, make sure the jacks are retracted before retracting the room.

2. Locate the HYDRAULIC PUMP/MANIFOLD unit.

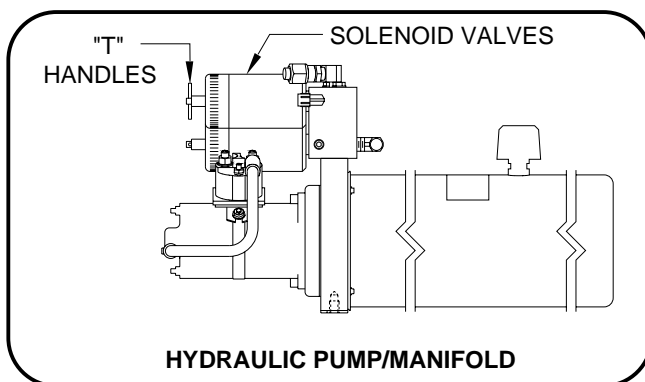

3. Open the SOLENOID VALVES by turning the "T" HANDLES counterclockwise.

NOTE : The "T" HANDLE may turn easily at first but will become more difficult to turn as an internal spring is compressed. Be sure to open both valves completely (about six turns of "T" HANDLE).

NOTE : The room may move slightly as the SOLENOID VALVES are opened and internal pressure is released.

4. Locate the MANUAL RETRACT WINCH and connect it to the room according to the vehicle manufacturer's instructions. To extend the WINCH STRAP firmly grasp WINCH HANDLE, place RATCHET LEVER in its OFF position, and slowly rotate the WINCH HANDLE counterclockwise, keeping a firm grip on the handle. When enough WINCH STRAP is extended, place the RATCHET LEVER in its ON position and slowly rotate the WINCH HANDLE clockwise until the RATCHET LEVER locks.

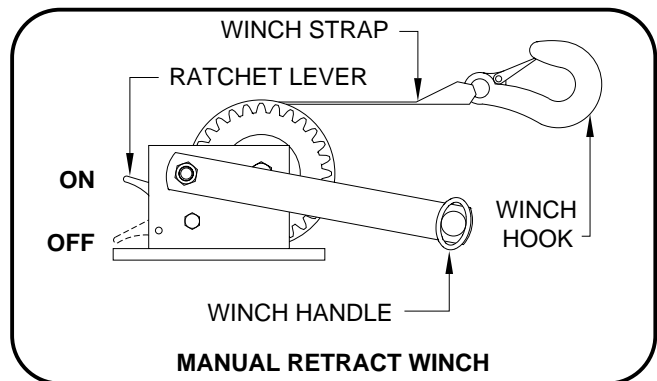

5. Slowly winch the room in by turning the WINCH HANDLE clockwise. The RATCHET LEVER should produce a loud, sharp, clicking noise.

NOTE : Winching the room in quickly will raise pressure in the hydraulic fluid and make winching more difficult.

CAUTION: OPERATE THE MANUAL RETRACT WINCH BY HAND POWER ONLY. IF THE WINCH CANNOT BE CRANKED EASILY WITH ONE HAND IT IS PROBABLY OVERLOADED. IF WINCHING BECOMES TOO DIFFICULT STOP AND CHECK FOR OBSTRUCTIONS OR RESTRICTIONS ON THE ROOM AND ROOM EXTENSION MECHANISM.

6. When the room is fully retracted, engage the room locking devices. Leave the retract winch in place.

CAUTION: THE ROOM EXTENSION SOLENOID VALVE "T" HANDLES MUST BE IN THE OPEN POSITION WHEN THE MANUAL RETRACT WINCH IS ENGAGED.

7. The system should be repaired before using again.

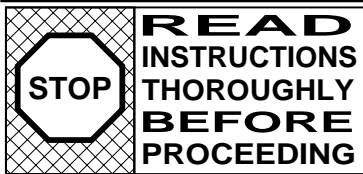

ROOM EXTENSION CYLINDER REPLACEMENT DUAL CYLINDER ROOM EXTENSION (WITH SYNCHRONIZING CYLINDER)

IMPORTANT: The following instructions must be followed or air lock of the synchronizing cylinder and unsynchronized operation of the room cylinders may result causing damage to the room. Please read the instructions before replacing the cylinder. **DO NOT** reverse direction of the room unless the room is fully extended or retracted until the room is running properly.

1. Extend the room fully. There is an access hole on the inner sliding tube to access the cylinder rod mounting nuts. If the room cannot be fully extended the inner sliding tube access hole must be extended far enough to access the cylinder rod mounting nuts.

2. Loosen the extend valve "T" Handle.

3. Loosen the retract valve "T" Handle.

4. Remove the two nuts and washers from the cylinder cap end mounting plate for both the front and rear room cylinders.

IMPORTANT: Step 4 must be done to protect the room from being damaged while bleeding air from and synchronizing the the room cylinders.

5. Remove the cylinder rod outer out stop adjusting nut for both the front and rear room cylinders.

6. Remove and cap the hoses at the end of the cylinder that is to be replaced.

7. Remove the cylinder that is to be replaced from the room extension tube.

NOTE: Do not remove the caps from the new cylinder hose connections until you are ready to reattach the hoses. Save the caps.

8. Remove the cylinder cap end mounting plate from the old cylinder and attach it to the new cylinder.

9. Install the inner out stop adjusting nut and lock washer completely onto the threaded rod of the new cylinder.

IMPORTANT: DO NOT PULL THE CYLINDER ROD OUT OF THE NEW CYLINDER. INSTALL THE NEW CYLINDER WITH THE ROD RETRACTED AS IT WAS SHIPPED.

IMPORTANT: BEFORE INSTALLING THE NEW CYLINDER, CLEAN ALL EXCESS OIL FROM THE ROOM EXTENSION TUBE. SWAB THE TUBE THOROUGHLY WITH A MILD SOLVENT AND RAGS. EXCESS OIL LEFT IN THE TUBE MAY LEAK OUT GIVING THE APPEARANCE OF A LEAKY CYLINDER OR HOSE CONNECTION.

10. Install the new cylinder in the room extension tube. **DO NOT** install the two cylinder cap end mounting plate nuts and washers.

11. Attach the hoses to the cylinder. Do not over tighten the hose ends. See MP45.9436 for tightening of hoses.

12. Remove Hose A from the room extension manifold. Use a cap from the new cylinder to cap the fitting in the manifold. Direct Hose A into the fluid reservoir.

13. Close the extend and retract valve "T" handles.

14. Push and hold the room control switch to "EXTEND" until the new cylinder is fully extended plus five seconds.

NOTE: The cap end of the cylinder will push the cylinder cap end mounting plate off the room extension tube. This is ok.

15. Reattach Hose A to the room extension manifold.

16. Push and hold the room control switch to "RETRACT" until both cylinders are fully retracted, plus 5 seconds. Extend and retract the cylinders at least twice or until they are running fully synchronized. **DO NOT** reconnect the cylinders until they are running fully synchronized.

CAUTION: DO NOT TRY TO LINE THE ROOM CYLINDER ROD UP WITH THE MOUNTING HOLE WHILE THE ROD IS EXTENDING.

17. Slide the cylinder rod through the rod mounting plate hole on the inner sliding tube. Install the nuts and lock washers on the cylinder cap end mounting plate. Turn the cylinder rod inner adjusting nut into place and install the cylinder rod outer adjusting nut. Make the nut snug only, as a final adjustment will have to be made. Do this for the front and rear cylinders.

IMPORTANT: Do not reverse direction of the room until the room is fully extended or retracted.

18. Push the room control switch to retract and hold until the room is fully retracted plus 5 seconds. Watch for excessive racking of the room. Some racking can occur do to air in the system. If the room starts to bind up, release the room control switch immediately. If the room does not bind up, proceed to Step 20. If the room is bound up, go to Step 19.

19. If the room is bound up, repeat Steps 4 and 5. Manually push the room out to its full extension. Now repeat Steps 15, 16, 17 and 18. If the room will still not run properly, contact HWH CORPORATION Customer Service at (800)321-3494 or at (563)724-3396.

20. Extend the room fully again. Do not reverse direction until the room is fully extended. Repeat retracting and extending the room several times being careful not to reverse directions until the room is fully extended or retracted.

21. With the room fully extended, check seals for proper compression. If the seal is not compressed or needs more compression, loosen the cylinder rod outer adjusting nut and tighten the cylinder rod inner adjusting nut. If the seal is compressed too much, loosen the cylinder rod inner adjusting nut and tighten the cylinder rod outer adjusting nut.

22. Check all hose connections and mounting nuts and bolts for tightness and leaks.

CYLINDER REPLACEMENT DUAL CYLINDER ROOM EXTENSION WITH SYNCHRONIZING CYLINDER

NOTE: ROD AND CAP END HOSE CONNECTIONS WILL BE THE SAME FOR MULTIPLE ROOM EXTENSIONS.

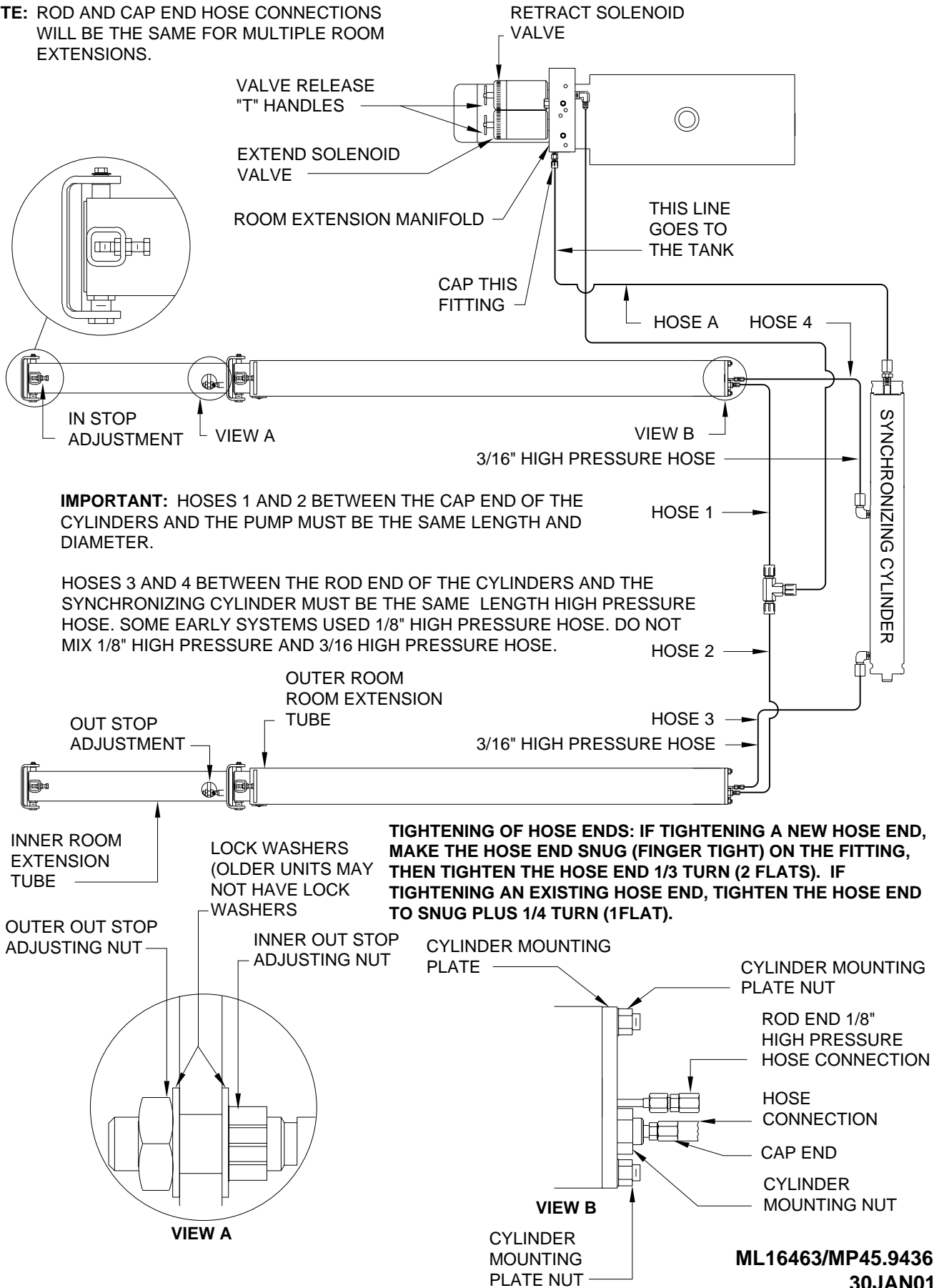



**READ
INSTRUCTIONS
THOROUGHLY
BEFORE
PROCEEDING**

ROOM EXTENSION CYLINDER REPLACEMENT DUAL CYLINDER VERTICAL ARM (WITH SYNCHRONIZING CYLINDER) (WITH ROOM EXTENSION MANIFOLD)

IMPORTANT: The following instructions must be followed or air lock of the synchronizing cylinder and unsynchronized operation of the room cylinders may result causing damage to the room. Please read the instructions before replacing the cylinder. **DO NOT** reverse direction of the room unless the room is fully extended or retracted until the room is running properly.

NOTE: Do not remove the caps from the new cylinder hose connections until you are ready to reattach the hoses. Save the caps.

1. Extend the room fully. Support the outer edge of the room so that the room cannot sag when the room extension arms are disconnected.
2. Loosen the extend valve "T" handle.
3. Loosen the retract valve "T" handle.
4. Remove coach equipment and panels to gain access to the front and rear room extension arm assemblies. Protect the coach interior from possible oil spillage.
5. Remove the pin plate from both room extension arms. This will allow both arms to move separately from the room.

IMPORTANT: Step 5 must be done to protect the room from being damaged while bleeding air from and synchronizing the the room cylinders.

NOTE: Only the faulty cylinder is to be removed from the room extension arm.

6. Remove and cap the hose from the rod end of the cylinder that is to be removed. Cut the wire ties holding the hose to the cylinder. There may be some pressure on the hoses.
7. Remove the four cylinder mounting bolts.
8. Work the cylinder out of the arm assembly. Remove and cap the hose from the cap end of the cylinder.

IMPORTANT: DO NOT PULL THE CYLINDER ROD OUT OF THE NEW CYLINDER. INSTALL THE NEW CYLINDER WITH THE ROD RETRACTED AS IT WAS SHIPPED.

9. Install the new cylinder. First attach the proper hose to the cap end of the cylinder. Do not over tighten the fittings.

Tightening of hose ends: If tightening a new hose end, make the hose end snug (finger tight) on the fitting, then tighten the hose end 1/3 turn (2 FLATS). If tightening an existing hose end, tighten the hose end to snug plus 1/4 turn (1 FLAT).

10. Install the cylinder into the arm assembly. Make sure the cap end hose is properly routed over the pivot pin as shown in the drawing.

11. Install the cap end trunion bolts. Make sure the bolts are properly seated into the groove at the cap end of the cylinder.

12. Attach the rod end hose to the cylinder. Do not over tighten the fitting. Wire tie the hose to the cylinder so it will not bind or be cut by the arm assembly.

13. Pull the arm assembly together and attach the rod end cylinder mounting nut to the arm.

14. Remove hose A from the pump. Remove the breather cap and direct hose A into the tank. Cap fitting A with a steel cap from the replacement cylinder.

15. Close the extend and retract valve "T" handles.

16. Push and hold the room control switch to "EXTEND" until the new cylinder is fully extended plus 3 to 5 seconds. Watch carefully that the cylinder does not extend too far.

17. Reattach hose A to fitting A.

18. Push and hold the room control switch to "RETRACT" until both arm assemblies are fully retracted. The new cylinder may not retract until the other arm is fully retracted.

19. Repeat extending and retracting the arms fully at least 3 more times or until the arms are completely synchronized. Do not go from "RETRACT" to "EXTEND" until the arms are fully retracted. Do not go from "EXTEND" to "RETRACT" until the arms are fully extended. Check that there are no leaks and that hose routings are ok.

20. Reattach the arms to the room with the pin plates.

21. Retract the room watching carefully that the room does not bind up. If the room binds up, DO NOT try to extend the room. Remove the pin plates and manually push the room out and support it. Repeat Steps 13 through 20. If the room will still not work properly, call HWH CORPORATION Customer Service at (800)321-3494 or at (563)724-3396.

22. If the room works properly extend and retract the room several times. Watch carefully that the room does not extend too far. Check that the room seals are properly compressed with the room extended. If the room needs to extend more, loosen the out stop cylinder adjustment jam nut. Use an allen wrench to turn the rod clockwise until the room is seated properly. Tighten the jam nut. If the room is extended too far, loosen the out stop cylinder adjustment jam nut and use an allen wrench to turn the rod counterclockwise until the room is properly seated. Tighten the jam nut.

23. Check again for leaks and hose routings. **Clean any oil spills.** Reinstall the coach interior.

CYLINDER REPLACEMENT VERTICAL ARM ROOM EXTENSION WITH SYNCHRONIZING CYLINDER

LEVELING SYSTEM
MANIFOLD OR
FITTINGS NOT SHOWN.

IMPORTANT: HOSES 1 AND 2 BETWEEN THE CAP END OF THE CYLINDERS AND THE PUMP MUST BE THE SAME LENGTH AND DIAMETER.

HOSES 3 AND 4 BETWEEN THE ROD END OF THE CYLINDERS AND THE SYNCHRONIZING CYLINDER MUST BE THE SAME LENGTH OF 3/16" HIGH PRESSURE HOSE. SOME OLDER SYSTEMS USED 1/8" HIGH PRESSURE HOSE. DO NOT MIX 1/8" HIGH PRESSURE AND 3/16" HIGH PRESSURE HOSE.

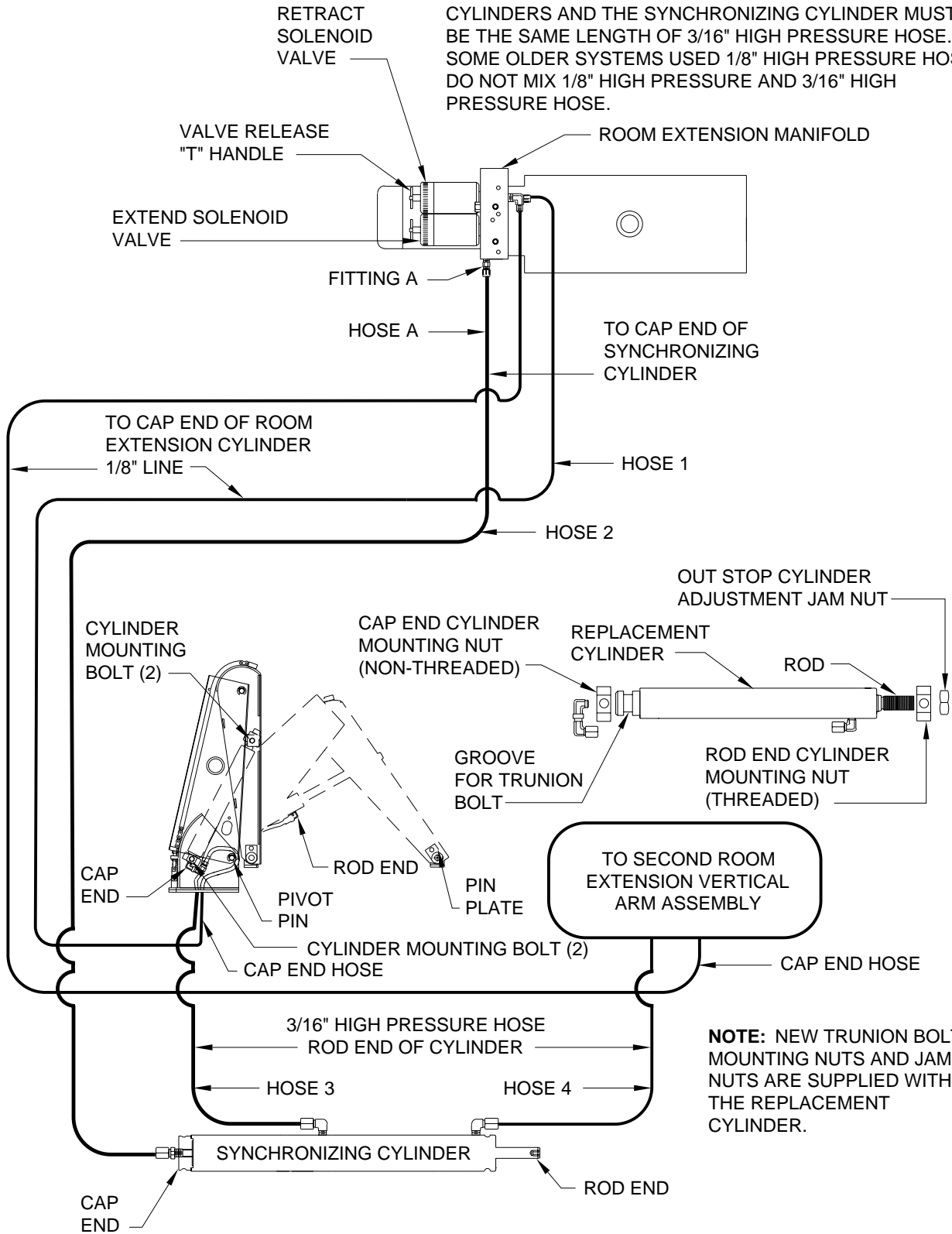



**READ
INSTRUCTIONS
THOROUGHLY
BEFORE
PROCEEDING**

ROOM ADJUSTMENT PROCEDURE VERTICAL ARM ROOM EXTENSION

IMPORTANT: The room should be properly adjusted to fit the vehicle and seal correctly when extended and retracted before leaving the factory. Changing adjustments in the field may cause the room to work improperly or change the way paint lines match up.

This sheet is meant to help make adjustments if a room is damaged or if a room extension mechanism is being replaced. Please contact the vehicle manufacturer before making adjustment.

NOTE: If a room extension cylinder is replaced, only the room extended stop adjustment should need to be made.

VERTICAL ADJUSTMENT ROOM EXTENDED (CHAIN ADJUSTMENT)

IMPORTANT: This adjustment should never be changed. Only make this adjustment if the complete arm assembly is being removed and replaced. At no time, whether the room is extended or retracted, should the chain be loose.

1. Point B should move parallel to the vehicle floor at the same height as point A.
2. If Point B should be raised, loosen the chain adjustment jam nut and tighten the chain adjustment nut.
3. If Point B should be lowered, loosen the chain adjustment jam nut and loosen the chain adjustment nut.
4. Tighten the chain adjustment jam nut when the adjustment is complete.

VERTICAL ADJUSTMENT ROOM RETRACTED

Make this adjustment if the room is not properly positioned up and down with the coach when the room is fully retracted.

1. There are two possible ways to make this adjustment. The bearing adjustment block is either shimmed or it has slotted bolt adjustments.
2. If the block is shimmed, add more shims as needed to lower the room. Remove shims if the room needs to be raised.
3. If the block has slotted bolts for adjustment, loosen the lower slotted bolt lock nut and turn the slotted end of the bolt clockwise to raise the room and counter clockwise to lower the room.
4. Tighten the slotted bolt lock nut when the adjustment is complete.

ROOM EXTENDED STOP ADJUSTMENT

Make this adjustment if the room is not properly sealed or if the interior trim is not properly positioned when the room is fully extended.

1. Loosen the extended stop jam nut.
2. Use a 5/16" hex key to turn the cylinder rod clockwise to move the room out or counter clockwise to move the room in.
3. Tighten the extended stop jam nut when the adjustment is complete.

ROOM RETRACTED STOP ADJUSTMENT

Make this adjustment if the room is not properly sealed or the outer room wall is not flush with the outside of the coach.

NOTE: The chain should not be slack in the retracted position. Readjust the retract stop bolts if the chain is loose.

1. Loosen the retract stop jam nuts.
2. Turn the retract stop adjustment bolts clockwise to adjust the room in and counter clockwise to adjust the room out. Both adjustment bolts must be in contact with the stop when adjusted.
3. Tighten the retract stop jam nuts when the adjustment is complete.

Contact HWH CORPORATION Customer Service for assistance at 1-800-321-3494 or 319-724-3396.

**ML18751/MP45.9449
14SEP99**

ROOM ADJUSTMENT PROCEDURES VERTICAL ARM ROOM EXTENSION

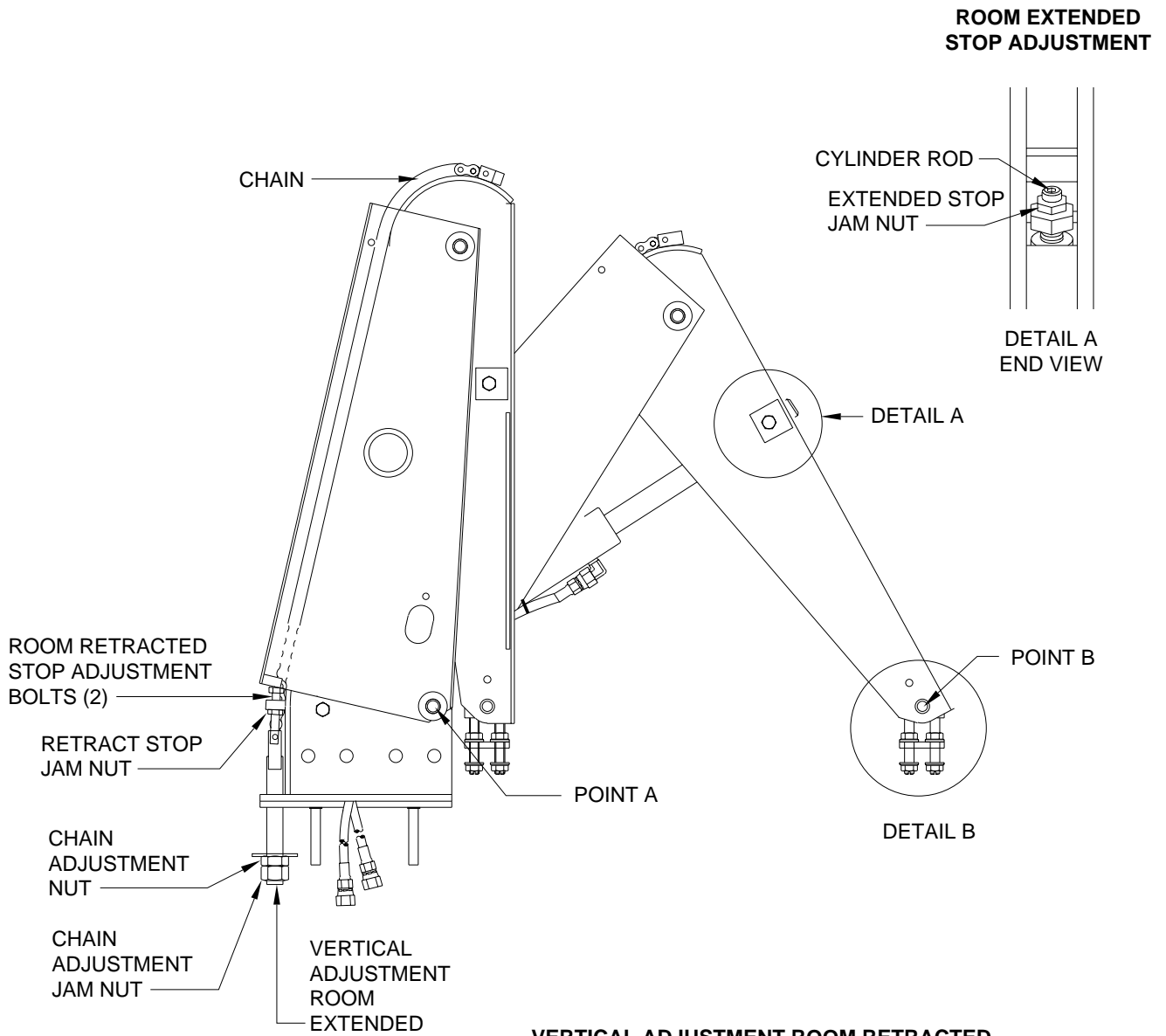

VERTICAL ADJUSTMENT ROOM RETRACTED

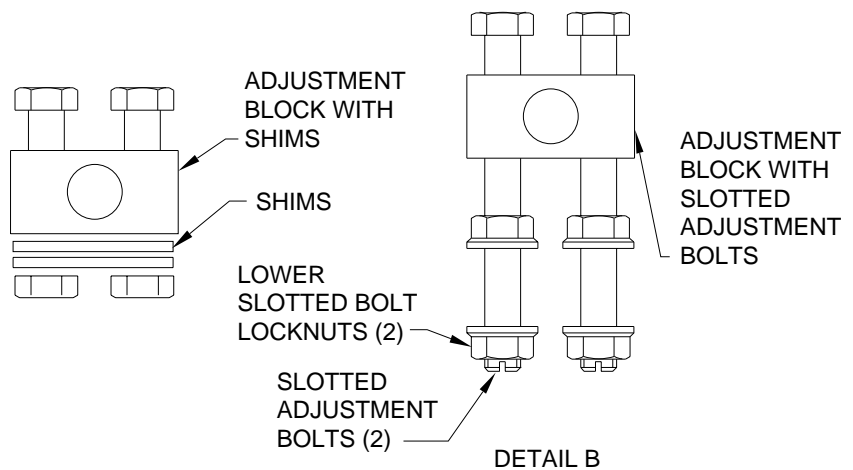

HYDRAULIC LINE CONNECTION DIAGRAM 310 SERIES LEVELING SYSTEM DUAL CYLINDER ROOM EXTENSION SYSTEM W/SYNCHRONIZING CYLINDER

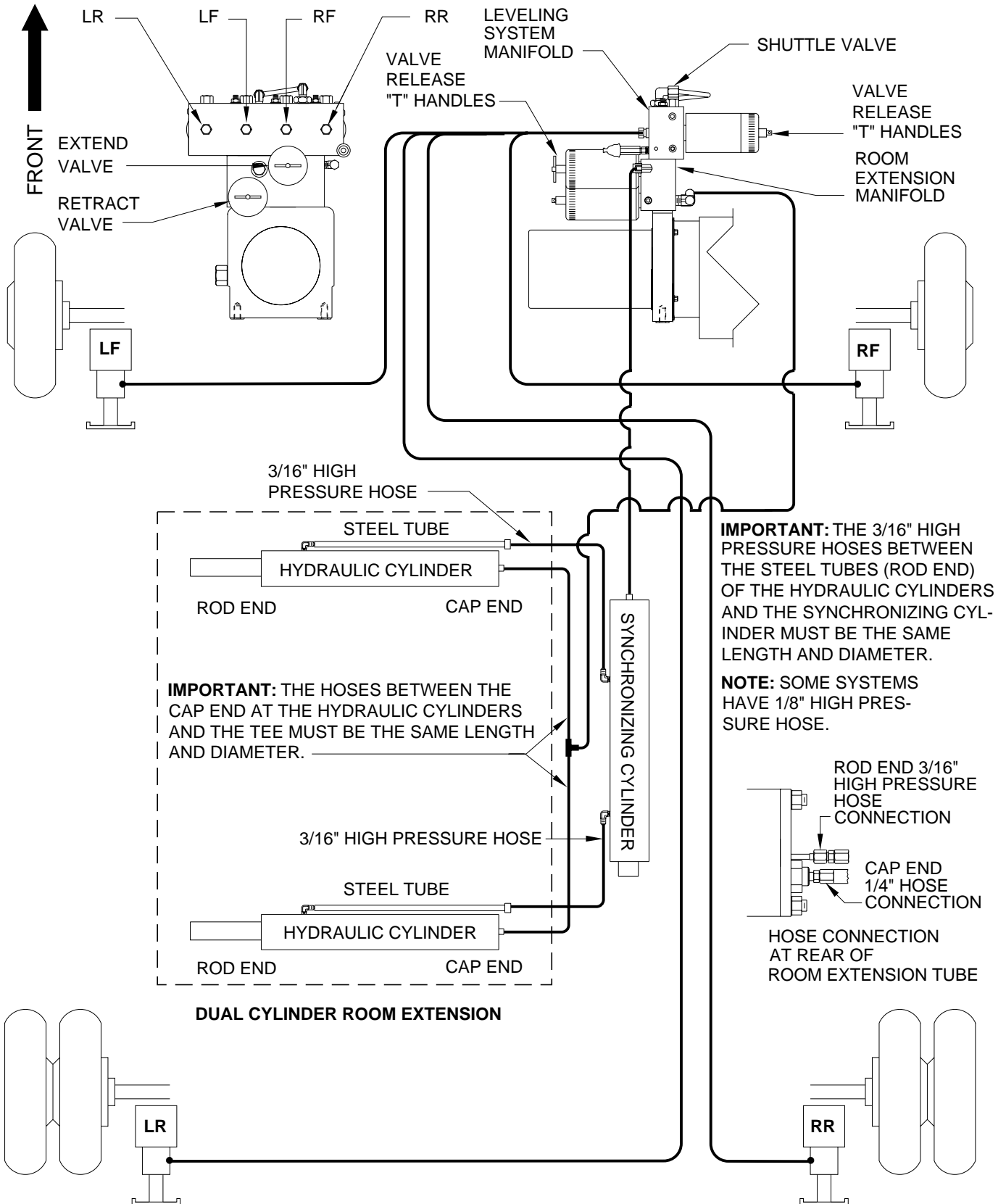

HYDRAULIC CONNECTION DIAGRAM VERTICAL ARM ROOM EXTENSION WITH SYNCHRONIZING CYLINDER

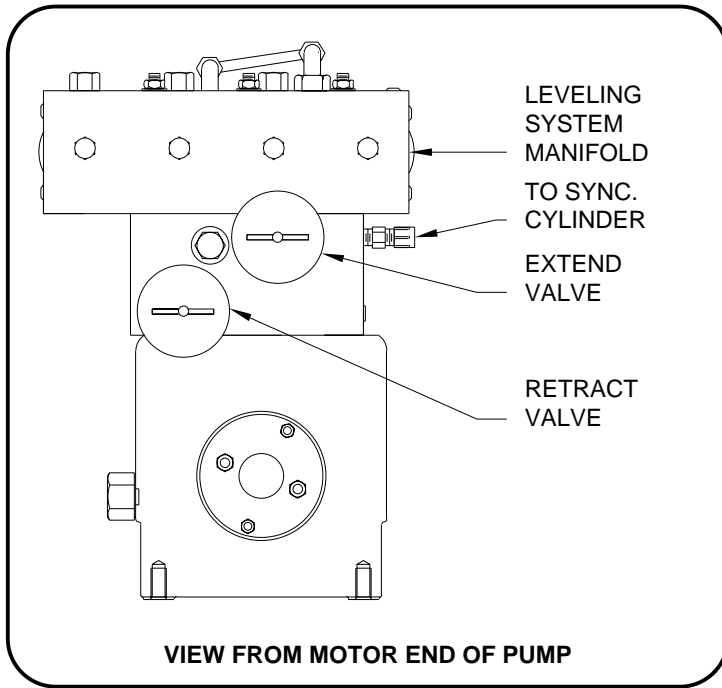

IMPORTANT: WHEN REPLACING THE HYDRAULIC HOSES, EXACT DIAMETER AND LENGTHS MUST BE MAINTAINED. DO NOT REPLACE AN 1/8" HIGH PRESSURE HOSE WITH A 3/16" HIGH PRESSURE HOSE.

NOTE: HYDRAULIC PUMP SHOWN WITH ROOM EXTENSION MANIFOLD ONLY. OTHER MANIFOLDS MAY BE MOUNTED ON TOP.

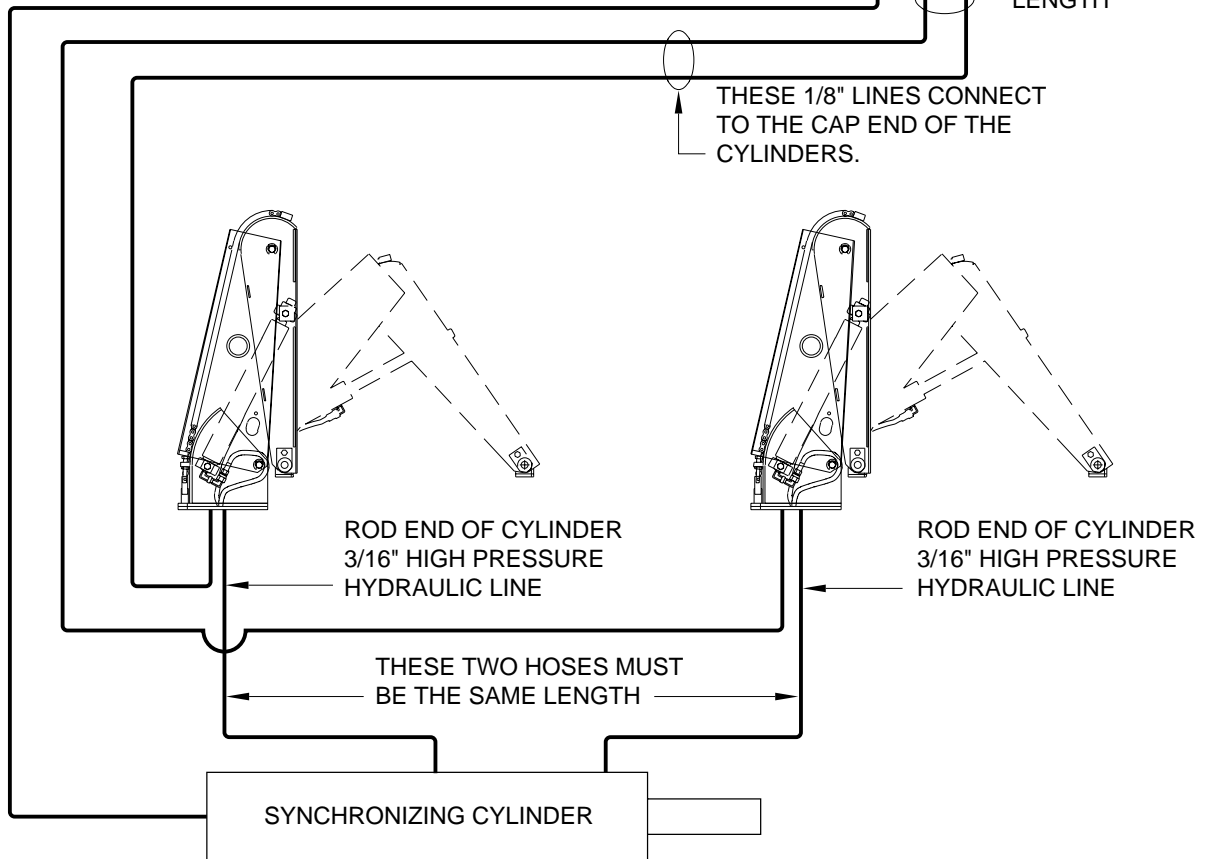
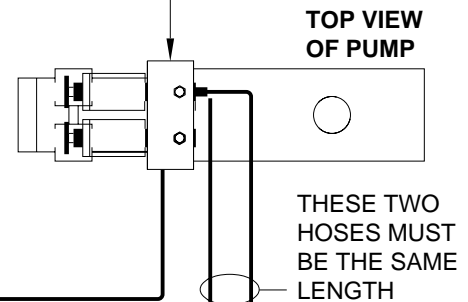

**HYDRAULIC FLOW DIAGRAM
VERTICAL ARM OR DUAL CYLINDER ROOM EXTENSION
WITH SYNCHRONIZING CYLINDER
STATIONARY POSITION**

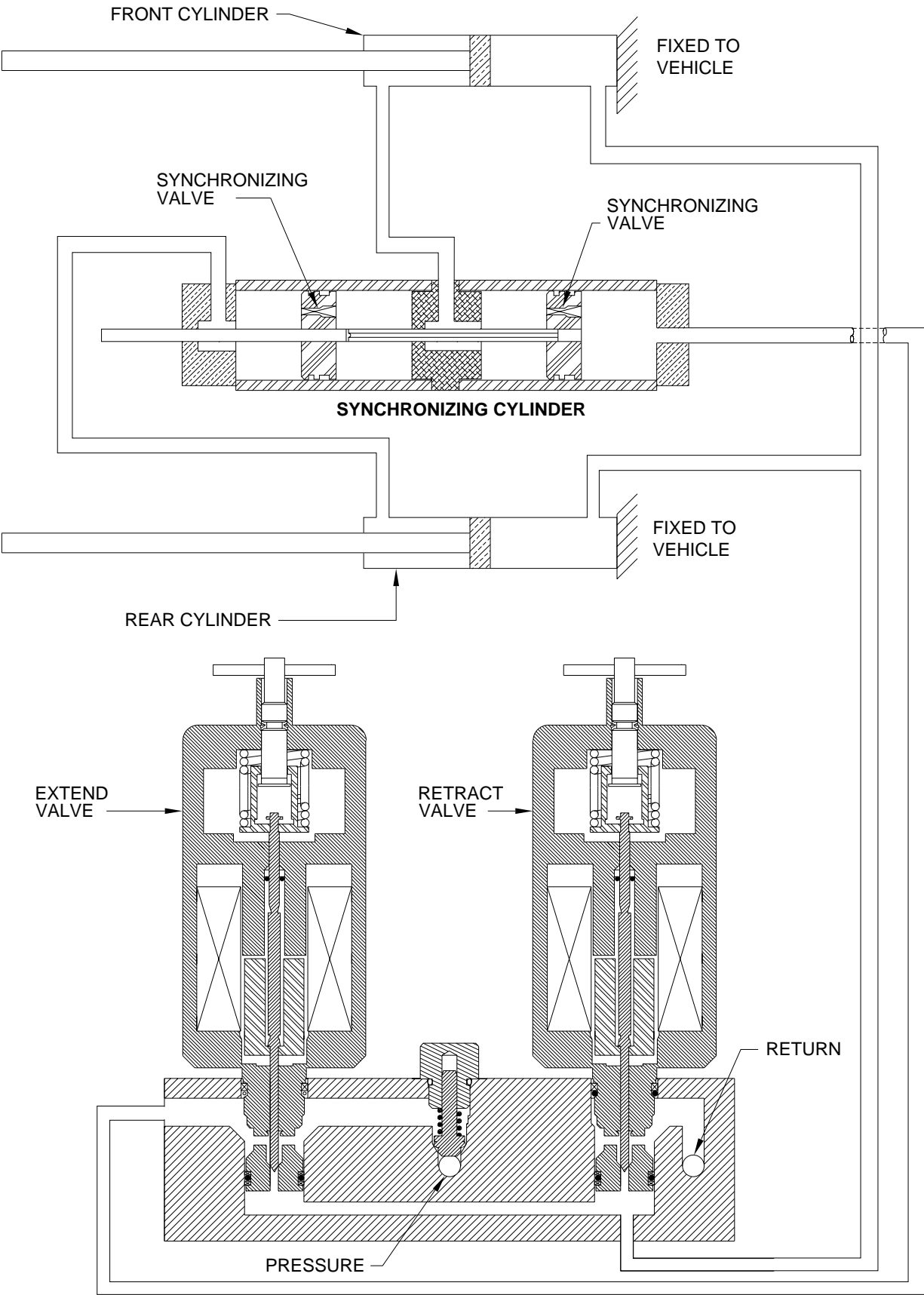

CONNECTION DIAGRAM

310 SERIES LEVELING SYSTEM TOUCH PANEL

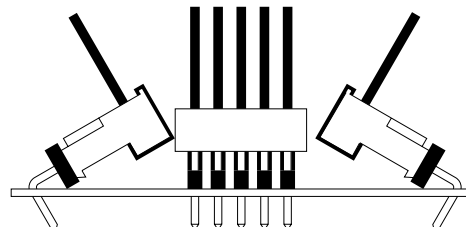
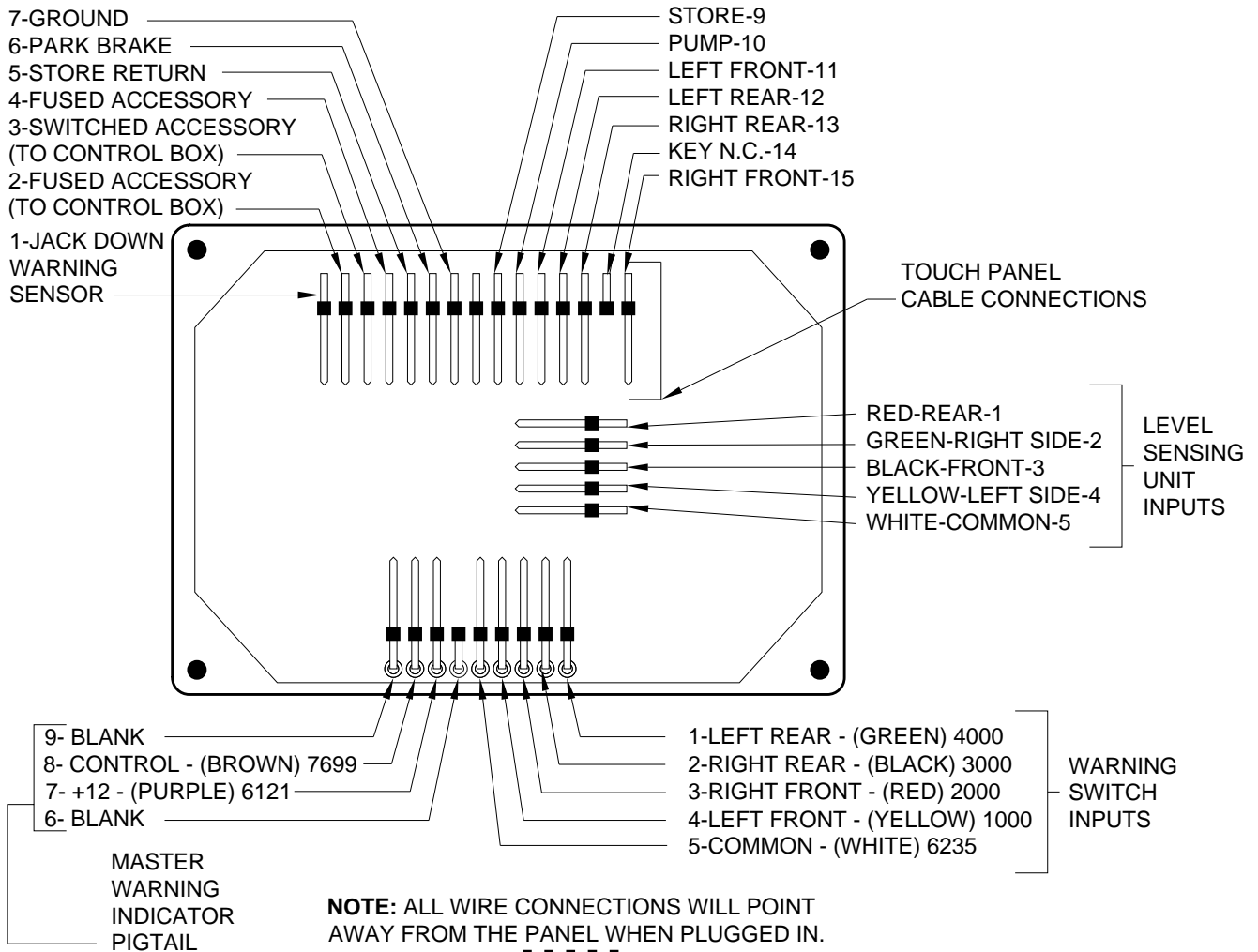
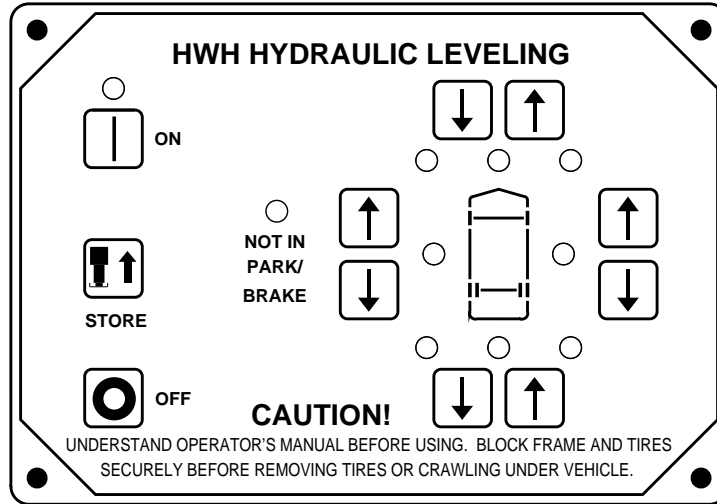

NOTE: THE (4) DIGIT WIRE NUMBER SUPERSEDES ANY AND ALL WIRE COLORS.

ELECTRICAL CONNECTION DIAGRAM CONTROL BOX 310 SERIES TOUCH PANEL-CONTROLLED LEVELING SYSTEM WITH ROOM EXTENSION

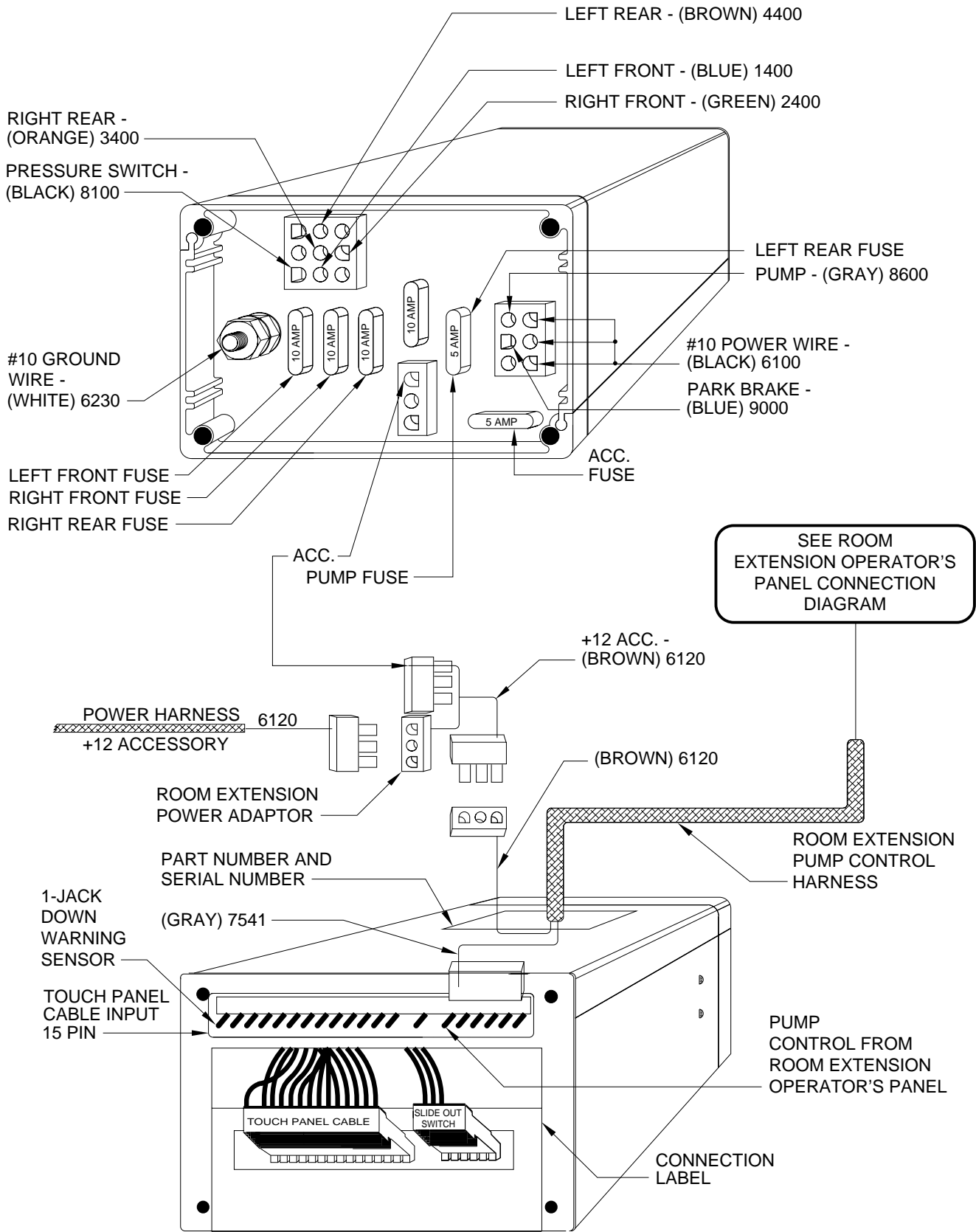

NOTE: THE (4) WIRE NUMBER SUPERSEDES ANY AND ALL WIRE COLORS.

PUMP RELAY WIRING DIAGRAM

NOTE: THE (4) DIGIT WIRE NUMBER
SUPERSEDES ANY AND ALL
WIRE COLORS.

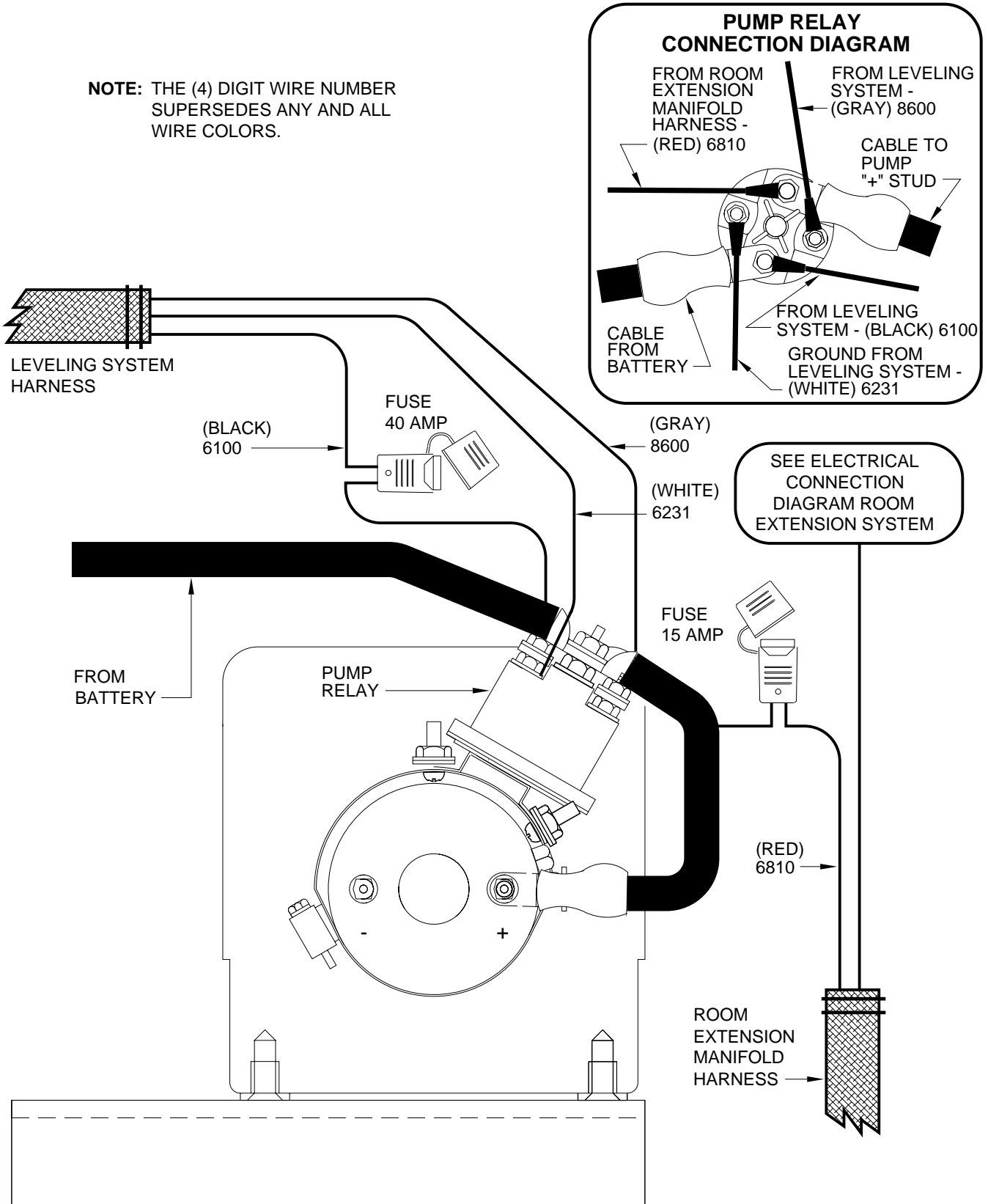

ELECTRICAL CONNECTION DIAGRAM ONE ROOM EXTENSION SYSTEM

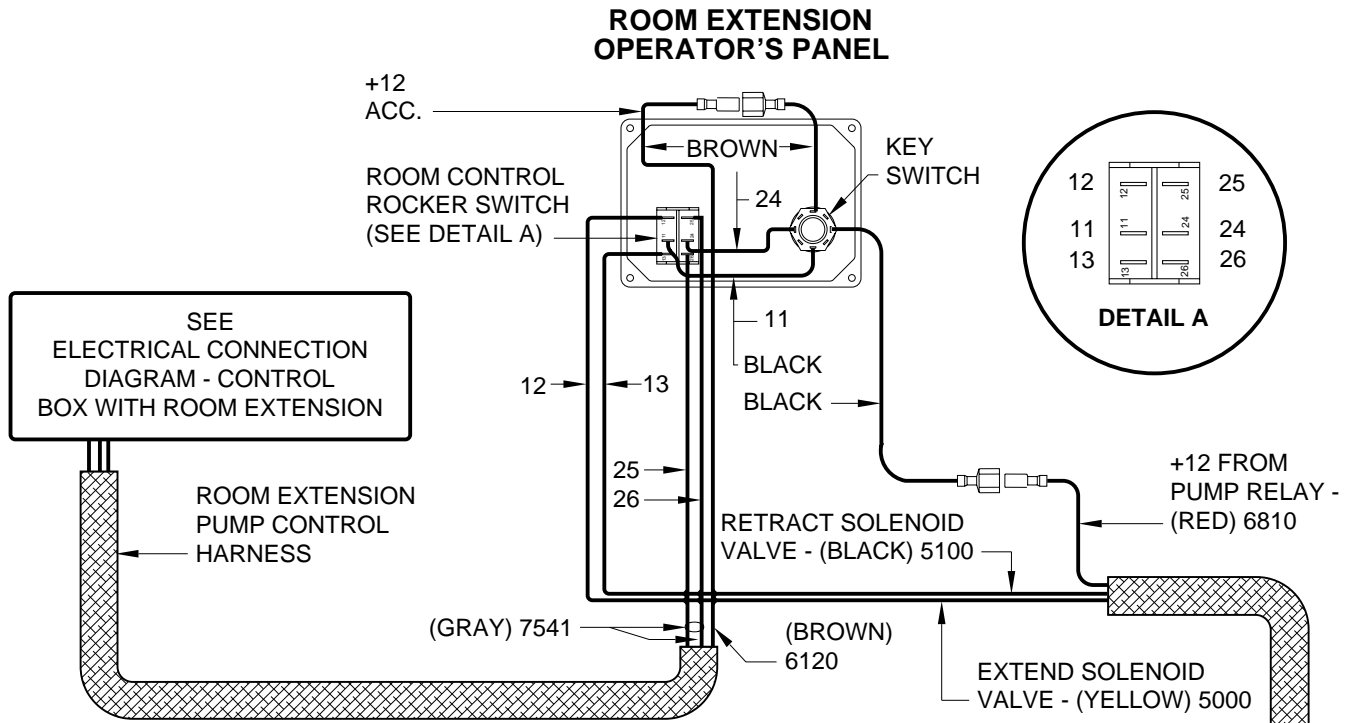

NOTE: THE (4) DIGIT WIRE NUMBER SUPERSEDES ANY AND ALL WIRE COLORS.

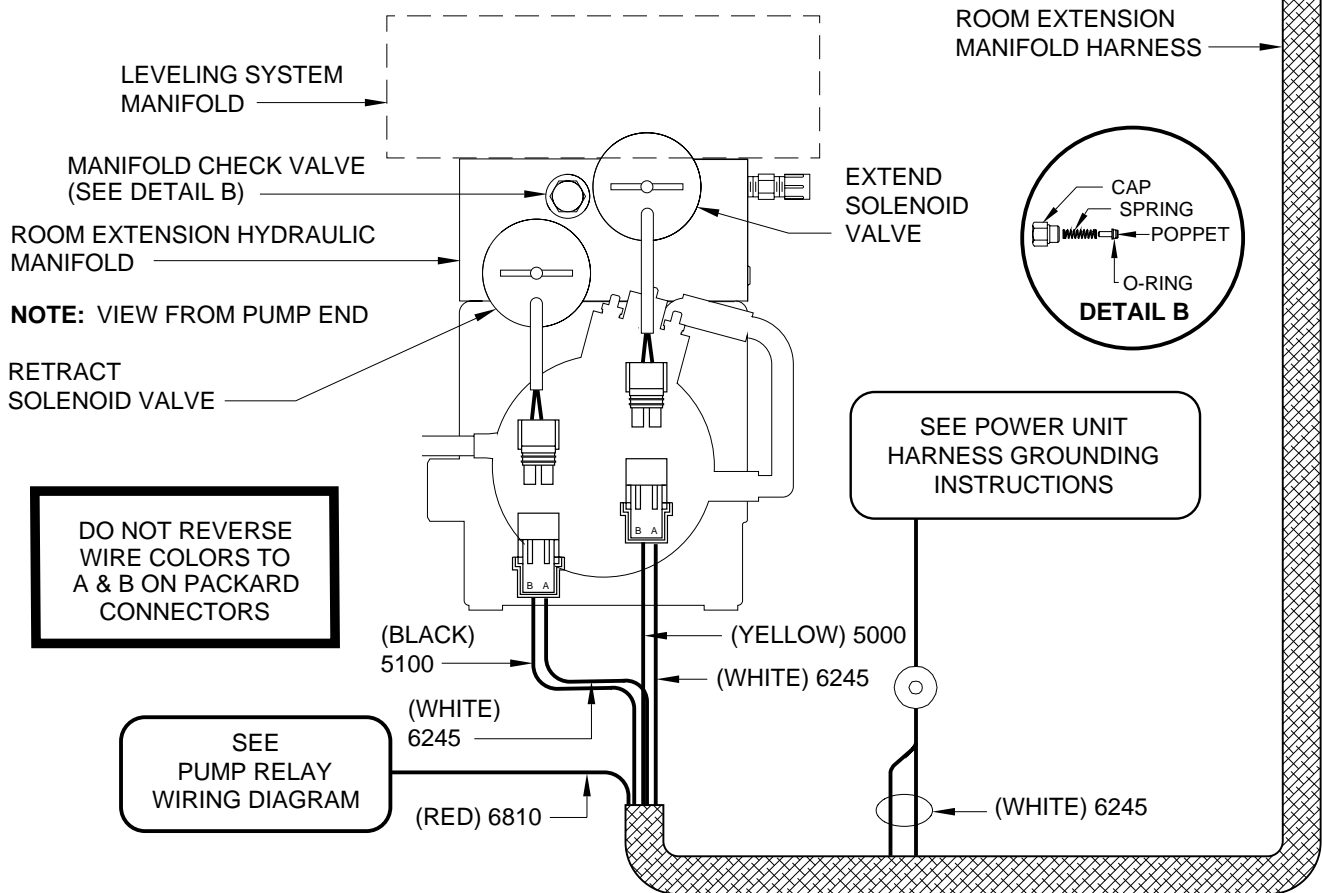

VIEW FROM PUMP END

**MP85.3038
25OCT99**

ELECTRICAL SCHEMATIC ROOM EXTENSION SYSTEM

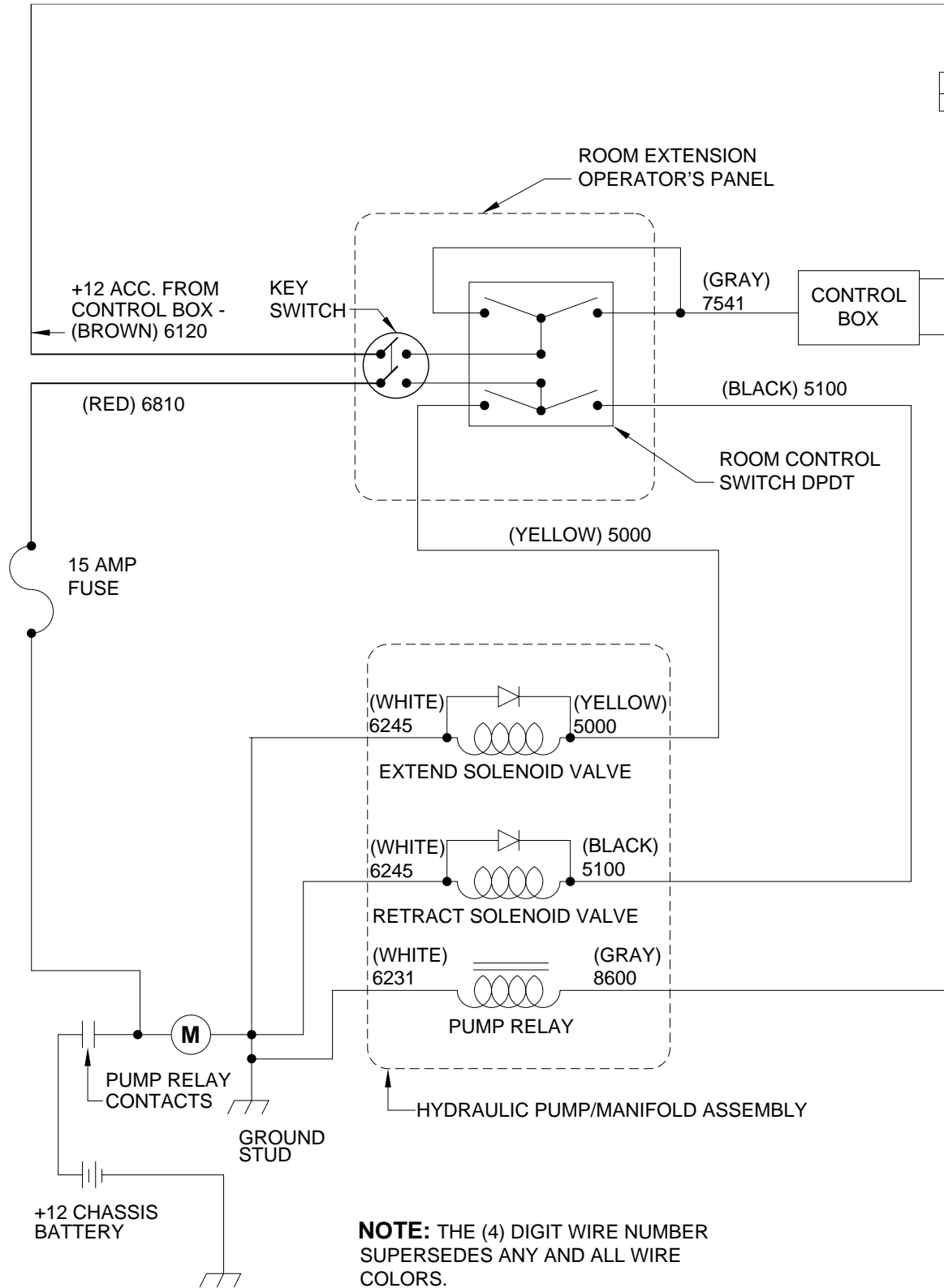

GROUNDING INSTRUCTIONS POWER UNIT/HARNESS 310 SERIES TOUCH PANEL-CONTROLLED LEVELING SYSTEM

WELDED PUMP MOUNT

USE GROUNDING STUD AND 3/8" EXTERNAL STAR LOCKWASHERS AS SHOWN.

IMPORTANT: 3/8" STAR LOCKWASHERS MUST BE USED BETWEEN GROUNDING SURFACE AND WIRE TERMINALS.

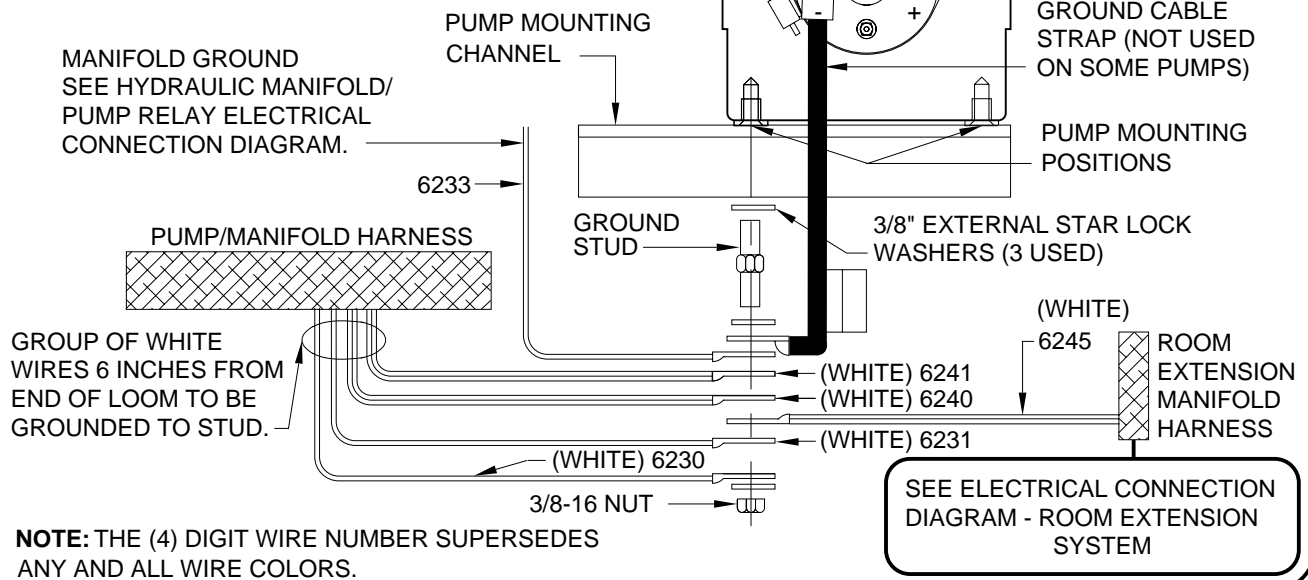

PUMP MOUNTED REMOTE FROM FRAME

USE GROUNDING STUD AND 3/8" EXTERNAL STAR LOCKWASHERS AS SHOWN.

IMPORTANT: 3/8" STAR LOCKWASHERS MUST BE USED BETWEEN GROUNDING SURFACE AND WIRE TERMINALS.

NOTE: THE (4) DIGIT WIRE NUMBER SUPERSEDES ANY AND ALL WIRE COLORS.

