

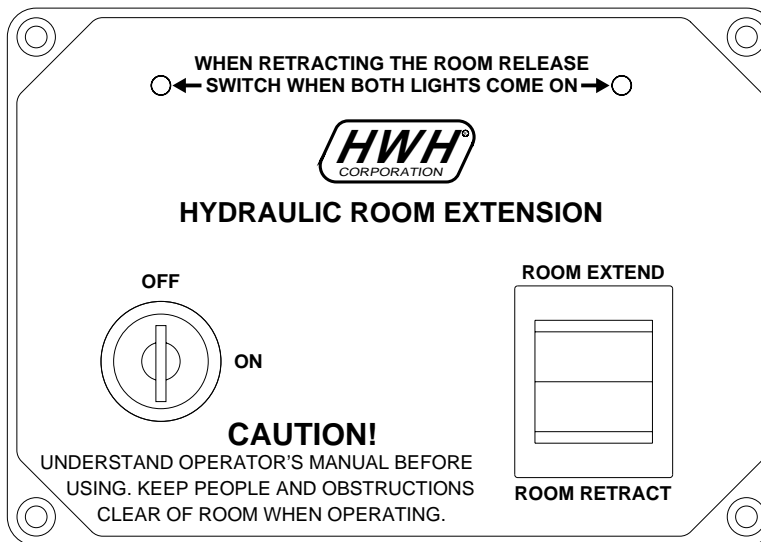

**AUTOMATIC TRAVEL CLAMP SCHEMATICS
WITH HWH ROOM EXTENSIONS
325 / 625 LEVELING SYSTEMS
OR
NO LEVELING SYSTEM**



CONTROL BOX AP29038

HWH CORPORATION
(On I-80, Exit 267 South)
2096 Moscow Road | Moscow, Iowa 52760
Ph: 800/321-3494 (or) 563/724-3396 | Fax: 563/724-3408
www.hwh.com

ELECTRICAL CONNECTION DIAGRAM

ROOM CLAMP CONNECTIONS

ROOM CONTROL PANEL ROOMS WITH TRAVEL CLAMPS

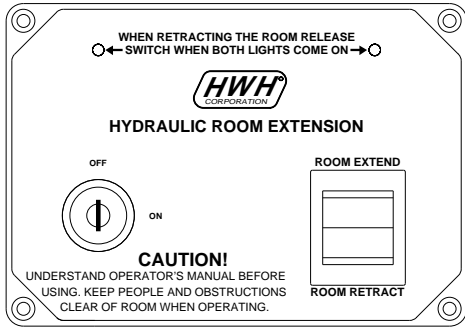

(REVERSE) ROOM CONTROL PANEL

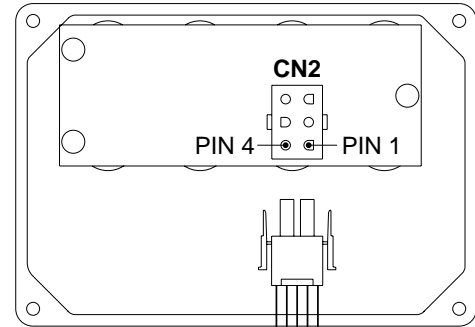

TO CN1 - CN2 OR CN3
ON 325 AND 625 MAIN
CONTROL BOXES

CLAMP CONTROL BOX

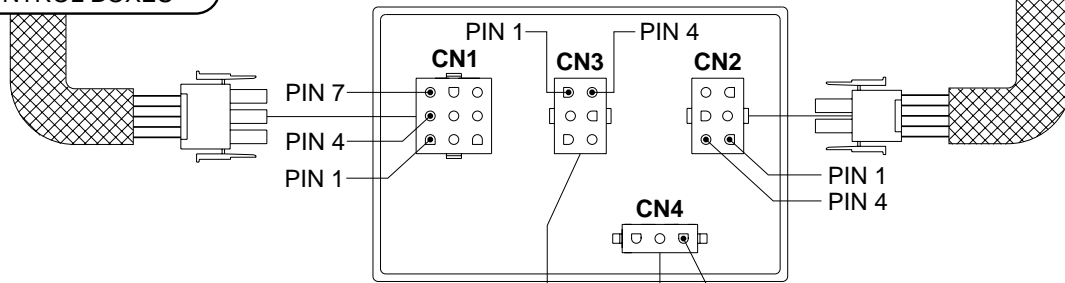

TO ROOM IN SWITCH.
NORMALLY OPEN
MAGNETIC SWITCH.
CONTACTS CLOSED
WHEN ROOM IS
RETRACTED

**NOTE: SW1 AND SW2 CLAMP LIMIT
SWITCHES ARE OPEN WHEN THE
CLAMP IS FULLY RETRACTED.**

LEFT ROOM CLAMP

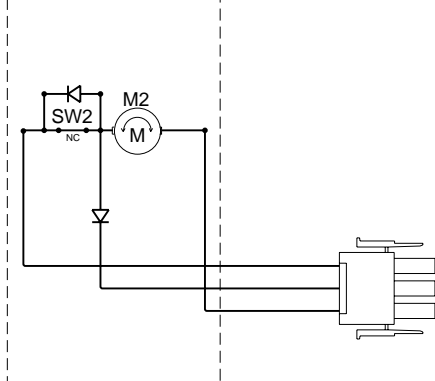

RIGHT ROOM CLAMP

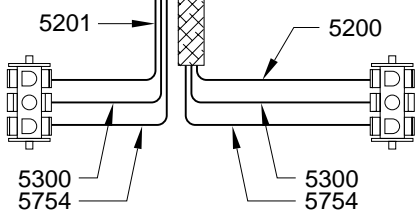
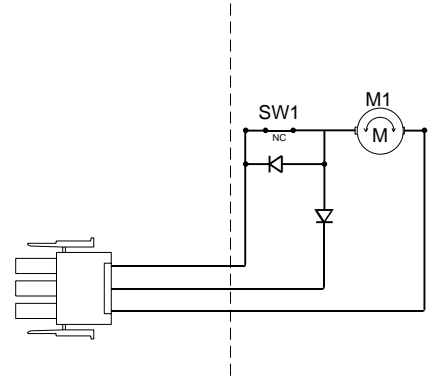

ELECTRICAL CONNECTION DIAGRAM

ROOM CONTROL PANEL - TRAVEL CLAMP CONTROL BOX - PIN OUTS

ROOM CONTROL PANEL

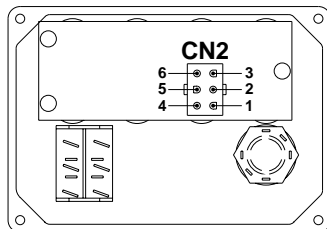

PIN #	WIRE COLOR	WIRE NUMBER	WIRE DESCRIPTION AND FUNCTION
CN2			6 PIN UML CONNECTOR
1	BLACK	5202	GROUND FOR ROOM PANEL INDICATOR LIGHTS RETRACT ONLY
2	RED	6100	+12 BATTERY TO ROOM CONTROL PANEL
3	BLACK	7501	SWITCHED +12 TO ROOM CLAMP CONTROL BOX ROOM EXTEND
4	BLACK	5200	+12 FOR RIGHT ROOM CLAMP INDICATOR LIGHT CLAMP EXTENDED
5	BLACK	7502	SWITCHED +12 TO ROOM CLAMP CONTROL BOX ROOM RETRACT
6	BLACK	5201	+12 FOR LEFT ROOM CLAMP INDICATOR LIGHT CLAMP EXTENDED

TRAVEL CLAMP CONTROL BOX

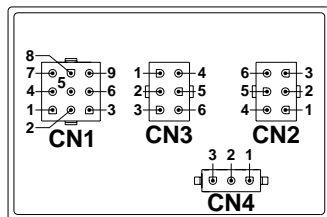

PIN #	WIRE COLOR	WIRE NUMBER	WIRE DESCRIPTION AND FUNCTION
CN1			9 PIN UML CONNECTOR
1	WHITE	6230	GROUND TO ROOM CLAMP CONTROL BOX
2	RED	6100	+12 BATTERY TO ROOM CLAMP CONTROL BOX
3	BLACK	5000	SWITCHED +12 TO MAIN CONTROL BOX ROOM EXTEND
4	WHITE	6230	GROUND TO ROOM CLAMP CONTROL BOX
5	RED	6100	+12 BATTERY TO ROOM CLAMP CONTROL BOX
6	BLACK	5100	SWITCHED +12 TO MAIN CONTROL BOX ROOM RETRACT
7	WHITE	6230	GROUND TO ROOM CLAMP CONTROL BOX
8	RED	6100	+12 BATTERY TO ROOM CLAMP CONTROL BOX
9	BLACK	8601	SWITCHED +12 TO MAIN CONTROL BOX PUMP CONTROL
CN2			6 PIN UML CONNECTOR
1	BLACK	5202	GROUND FOR ROOM PANEL INDICATOR LIGHTS RETRACT ONLY
2	RED	6100	+12 BATTERY TO ROOM CONTROL PANEL
3	BLACK	7501	SWITCHED +12 TO ROOM CLAMP CONTROL BOX ROOM EXTEND
4	BLACK	5200	+12 FOR RIGHT ROOM CLAMP INDICATOR LIGHT CLAMP EXTENDED
5	BLACK	7502	SWITCHED +12 TO ROOM CLAMP CONTROL BOX ROOM RETRACT
6	BLACK	5201	+12 FOR LEFT ROOM CLAMP INDICATOR LIGHT CLAMP EXTENDED
CN3			6 PIN UML CONNECTOR
1			NO CONNECTION
2	BLACK	5754	CLAMP LIMIT SWITCHES - (+12) WITH CLAMP EXTENDED
3	BLACK	5300	CLAMP EXTEND (+12) - CLAMP RETRACT (GROUND)
4	BLACK	5200	RIGHT CLAMP RETRACT (+12) - RIGHT CLAMP EXTEND (GROUND)
5	BLACK	5201	LEFT CLAMP RETRACT (+12) - LEFT CLAMP EXTEND (GROUND)
6	BLACK	5300	CLAMP EXTEND (+12) - CLAMP RETRACT (GROUND)
CN4			3 PIN UML CONNECTOR
1			NO CONNECTION
2	BLACK	5702	SWITCHED +12 WITH ROOM IN
3	BLACK	6121	SWITCHED +12 BATTERY TO ROOM IN SWITCH (RETRACT ONLY)

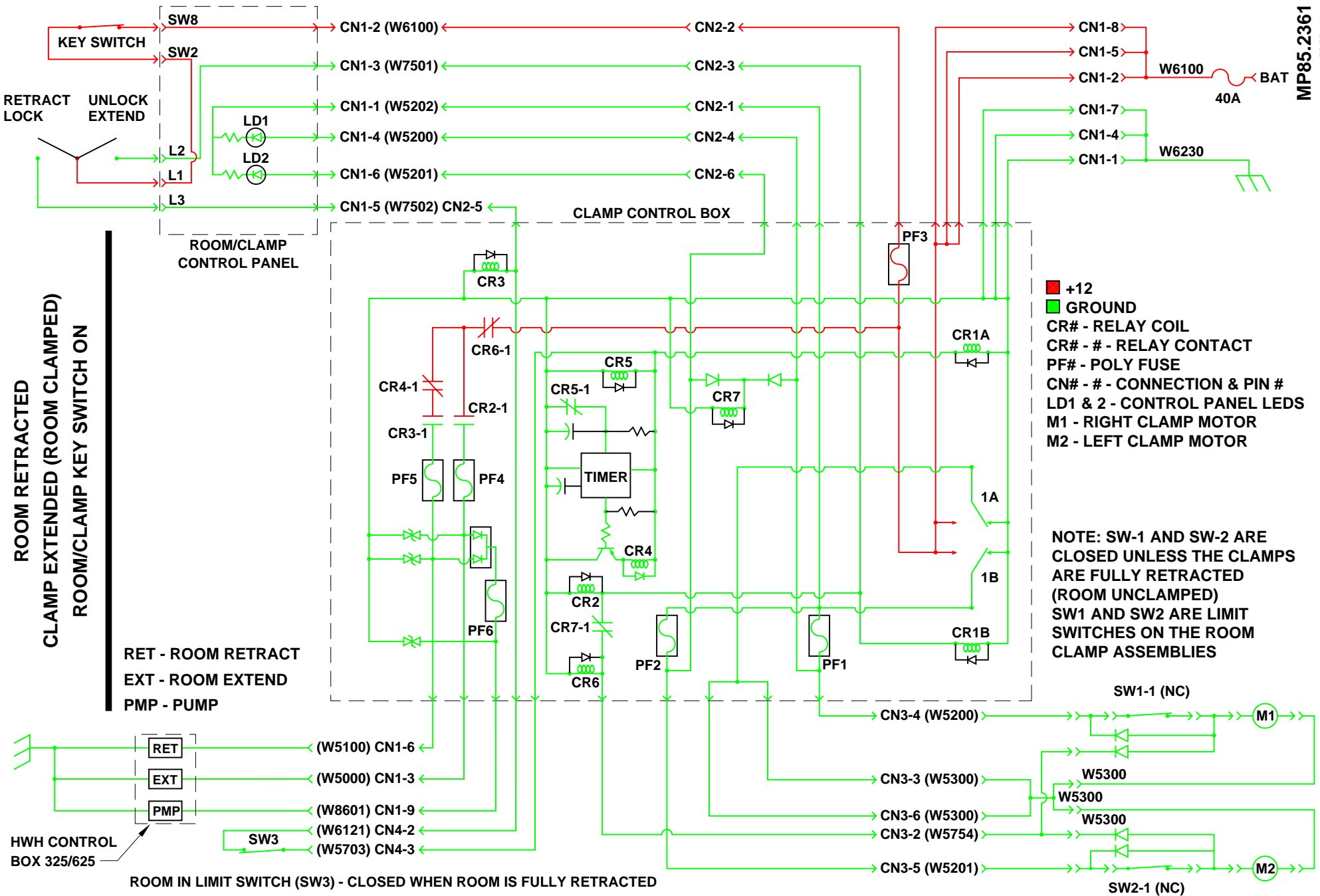

- +12
- GROUND
- CR# - RELAY COIL
- CR# - # - RELAY CONTACT
- PF# - POLY FUSE
- CN# - # - CONNECTION & PIN #
- LD1 & 2 - CONTROL PANEL LEDS
- M1 - RIGHT CLAMP MOTOR
- M2 - LEFT CLAMP MOTOR

NOTE: SW-1 AND SW-2 ARE CLOSED UNLESS THE CLAMPS ARE FULLY RETRACTED (ROOM UNCLAMPED)
SW1 AND SW2 ARE LIMIT SWITCHES ON THE ROOM CLAMP ASSEMBLIES

RET - ROOM RETRACT
EXT - ROOM EXTEND
PMP - PUMP

ROOM IN LIMIT SWITCH (SW3) - CLOSED WHEN ROOM IS FULLY RETRACTED

ROOM RETRACTED (ROOM CLAMPED)
CLAMP EXTENDED (ROOM CLAMPED)
ROOM/CLAMP KEY SWITCH ON

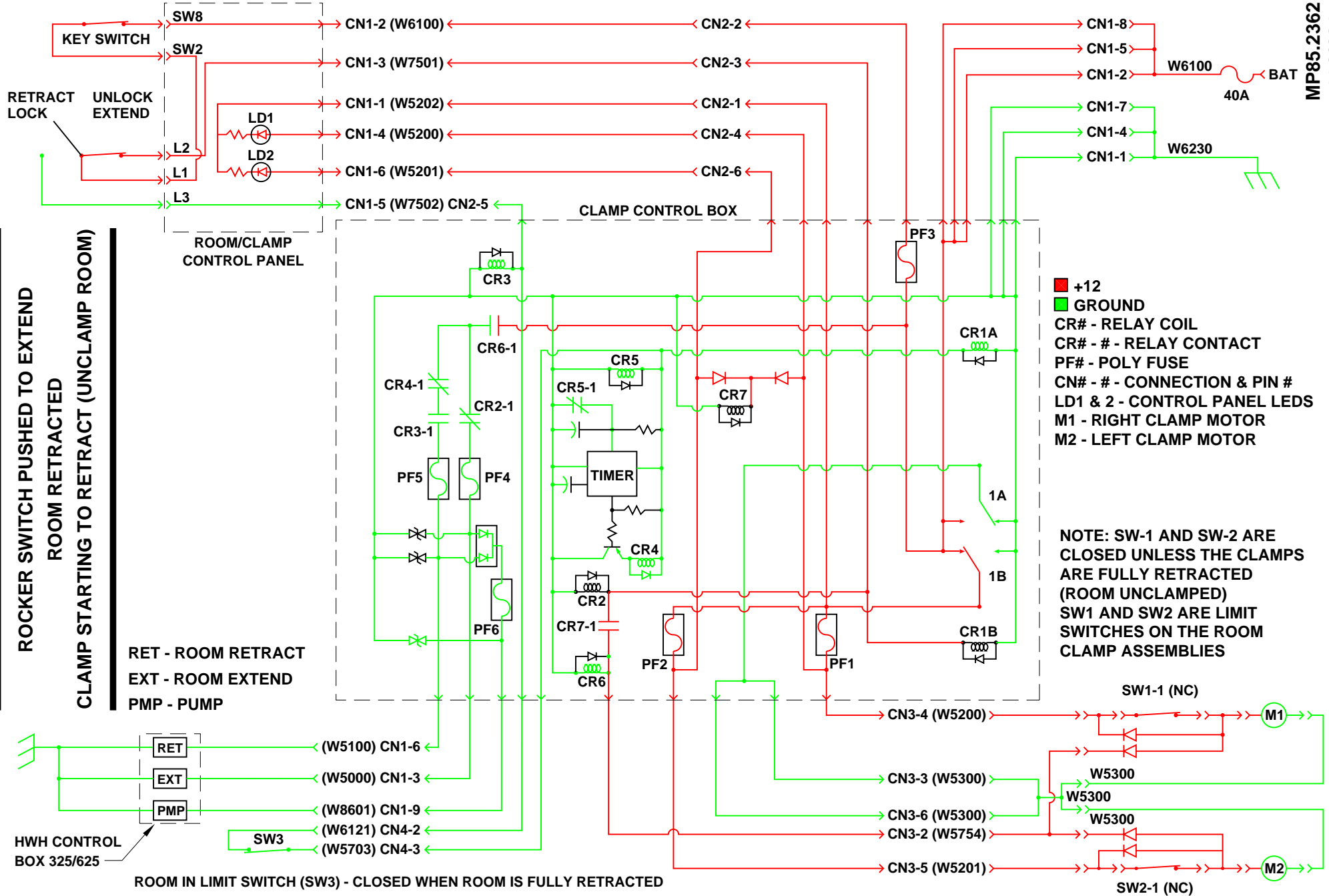

- +12
- GROUND
- CR# - RELAY COIL
- CR# - # - RELAY CONTACT
- PF# - POLY FUSE
- CN# - # - CONNECTION & PIN #
- LD1 & 2 - CONTROL PANEL LEDS
- M1 - RIGHT CLAMP MOTOR
- M2 - LEFT CLAMP MOTOR

NOTE: SW-1 AND SW-2 ARE CLOSED UNLESS THE CLAMPS ARE FULLY RETRACTED (ROOM UNCLAMPED)
SW1 AND SW2 ARE LIMIT SWITCHES ON THE ROOM CLAMP ASSEMBLIES

RET - ROOM RETRACT
EXT - ROOM EXTEND
PMP - PUMP

ROOM IN LIMIT SWITCH (SW3) - CLOSED WHEN ROOM IS FULLY RETRACTED

ROCKER SWITCH PUSHED TO EXTEND
ROOM RETRACTED
CLAMP STARTING TO RETRACT (UNCLAMP ROOM)

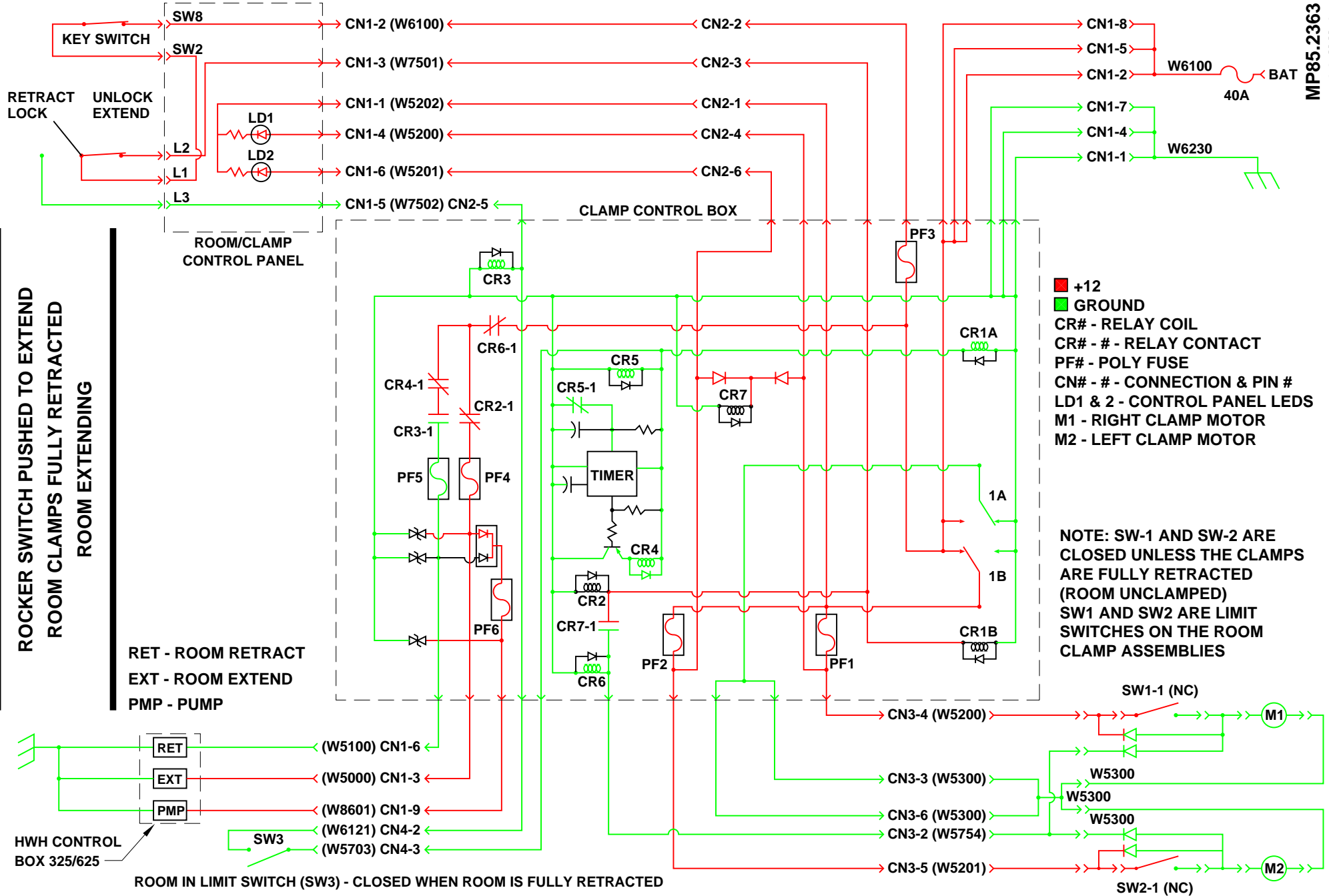

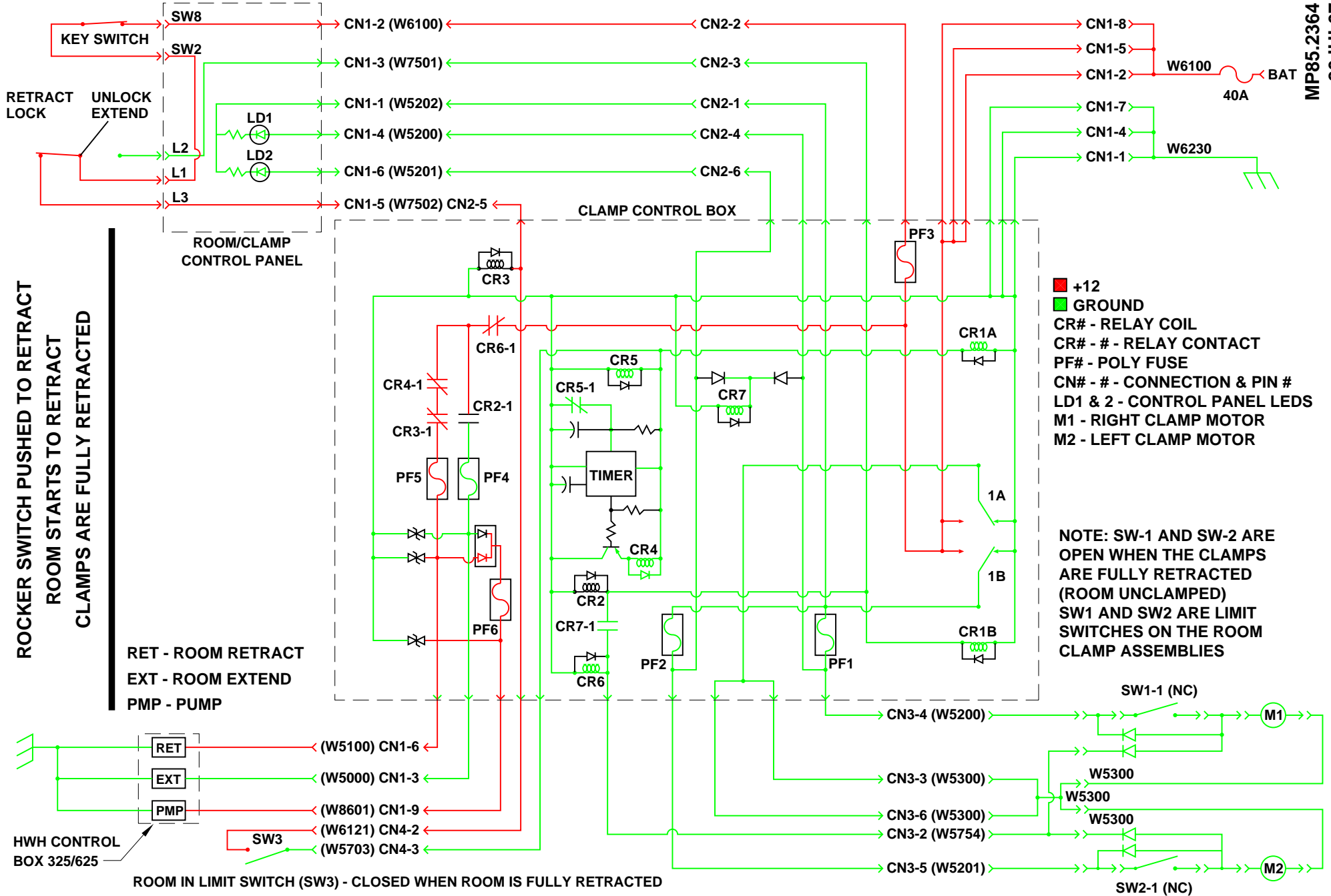

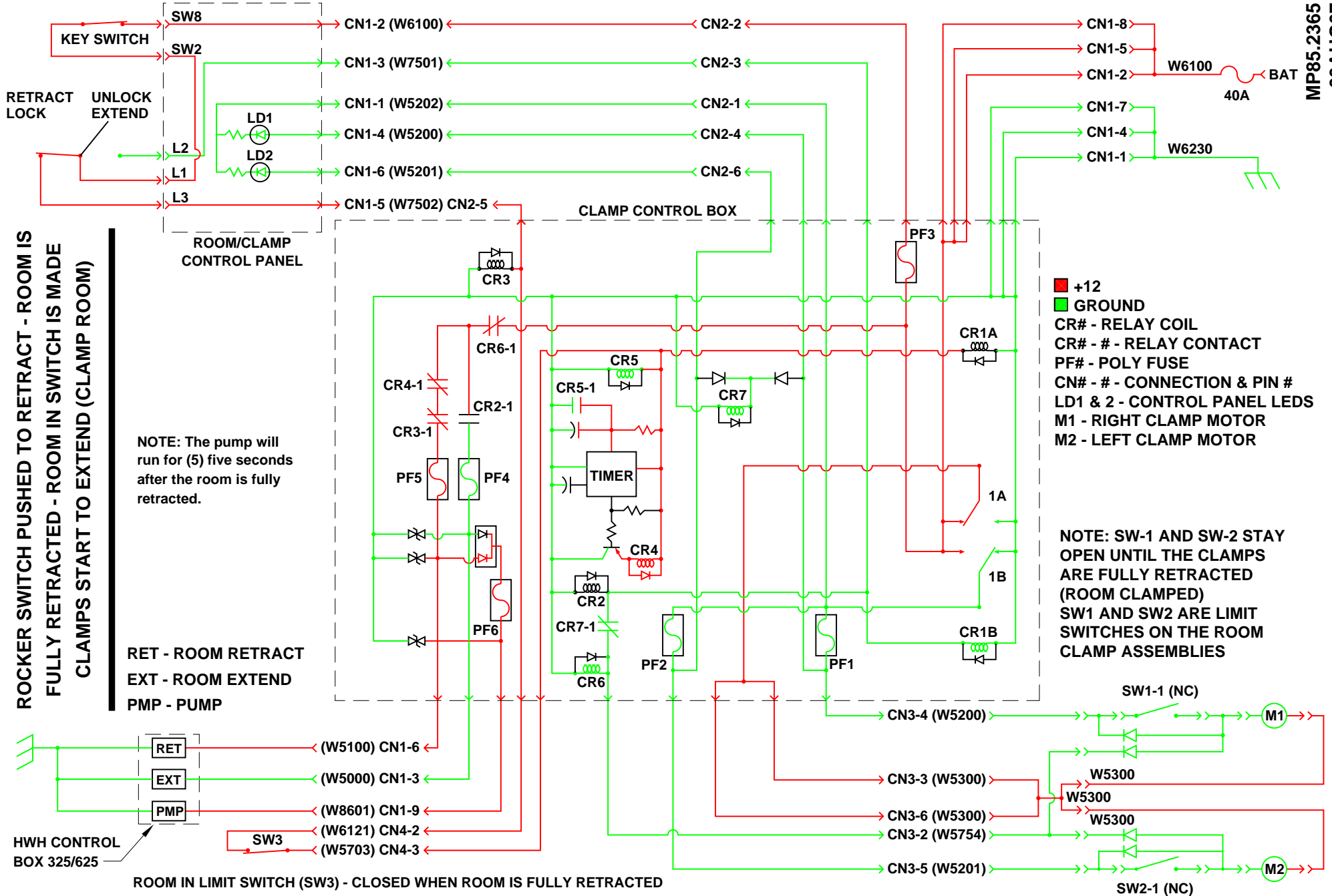

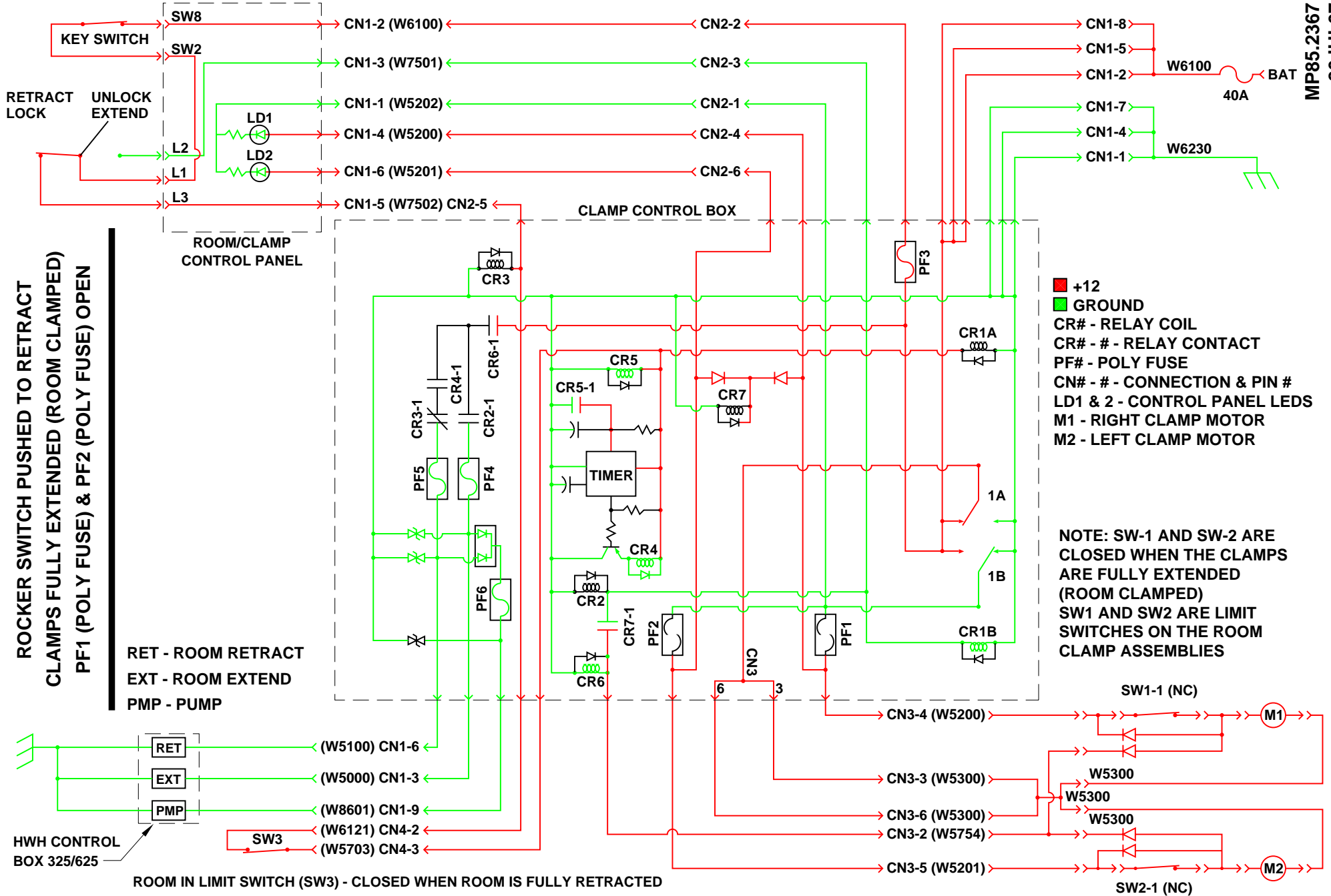

ROOM IN LIMIT SWITCH (SW3) - CLOSED WHEN ROOM IS FULLY RETRACTED