

# BOX, CONTROL FOR COMPUTER-CONTROLLED (TOUCH PANEL) LEVELING SYSTEMS (USE BEGINNING IN 1991)

## 510 SERIES WITH MODULAR CABLE

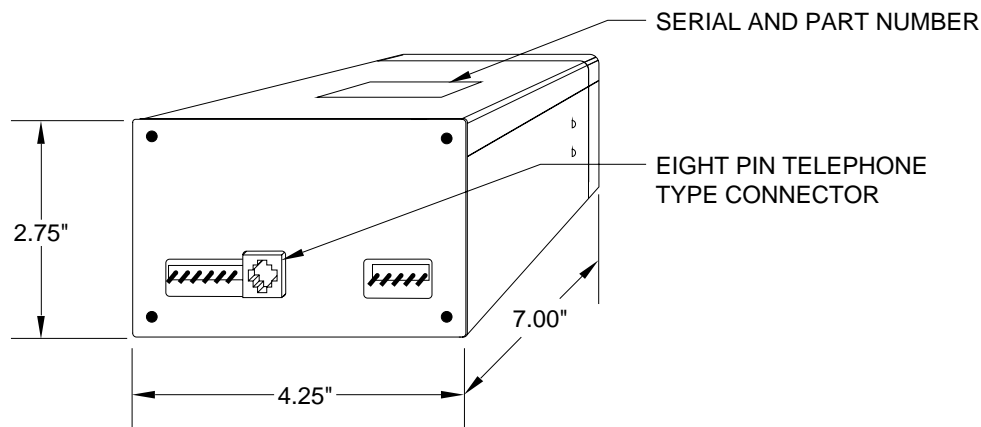
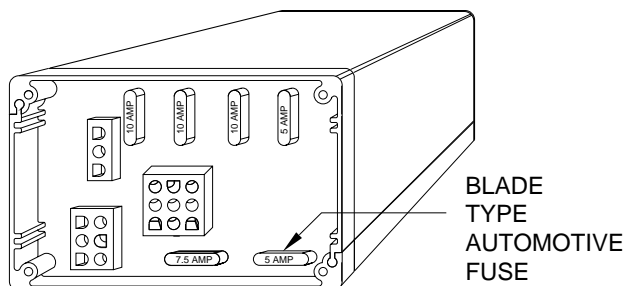

### REPLACEMENT CONTROL BOXES

*EXISTING NUMBER	HYDRAULIC LEVELING	JACK STYLE	AIR DUMP	AIR LEVELING	PARK SIGNAL	OPERATION FEATURES	**COMMON APPLIC.	REPLACE NUMBER
AP7855 or AP8478	YES	2 or 4 KD	YES	NO	NEG.	2-3 JACKS	ELITE	RAP8478
AP7865 or AP8465	YES	2 or 4 KD	NO	NO	NEG.	2-1 JACKS	FLEETWOOD ELITE	RAP8465
AP8055	YES	4-ST	NO	NO	NEG.	2-1 JACKS	BLUEBIRD	RAP8055
AP8075	YES	4-ST	YES	NO	NEG.	2-3 JACKS	FORETRAVEL	RAP8075
AP8717	YES	2 or 4 KD	NO	NO	NEG.	2-1 JACKS 30 S. STAB		RAP8717
AP8812	YES	4-ST	NO	NO	NEG.		MART-MARI MID-WELD	RAP8812

\* PART NUMBER IS ON TOP OF BOX. NUMBER BEGINS WITH "AP" FOLLOWED BY 4 OR 5 NUMERALS.  
 \*\* SOME VEHICLES MAY HAVE DIFFERENT CONTROL BOXES.