

The HWH[®] SpaceMaker[®] Dual-Cylinder “Level Out” Hydraulic Room Extension (with HWH Synchronizing Cylinder)

This room extension mechanism is designed to create a flush floor between the slide-out room and the RV floor while the room is in the extended (out) position. It eliminates the “step up” into the slide-out room where the floors meet.

The “Level Out” SpaceMaker consists of two hydraulic extension cylinders positioned within two main members. The simultaneous extension & retraction movements of the hydraulic cylinders are controlled by our exclusive **HWH Synchronizing Cylinder** --- this allows for smooth, even extension and retraction of the room and... Because the Synchronizing Cylinder eliminates the need for a cross shaft tying the mechanisms together, the space between the mechanisms is left free for storage compartments.

HWH extension hydraulics provide precise compression on the room seals so that the room closes firmly and securely. Cylinder strokes can be adjusted in either direction so that the room continues to seal over time.

Like HWH Leveling Systems, you'll find technology-driven engineering and high quality material. No wonder HWH Room Extensions and Leveling Systems are the right combination. For reliability and durability, depend on HWH. No one else measures up.

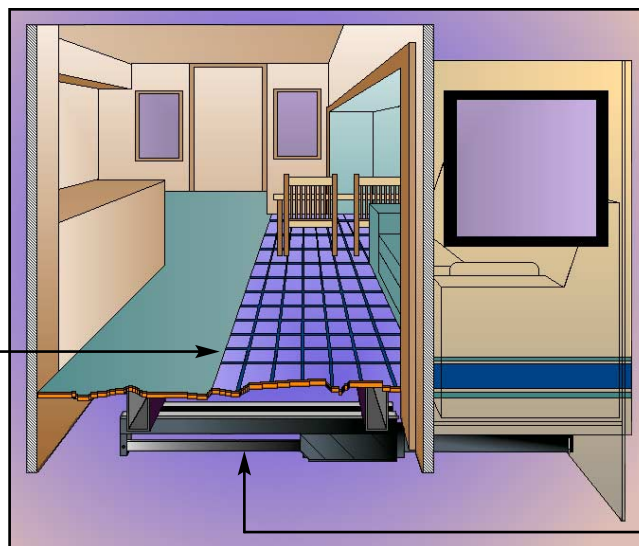

The Hydraulic Cylinders are located inside of the two main members, located at each end of the room.

Room Extension Mechanism Assembly

SpaceMaker[®] Control Panel

The HWH SpaceMaker[®] is operated with the use of a momentary switch. *To operate, simply insert the key into the ON/OFF Key Switch and turn key to the “ON” position. Then, press the Momentary Switch in the “EXTEND” position until the room

is extended to the desired position. To complete the process, turn the key to the “OFF” position and remove. To retract the room, simply reverse the operations.

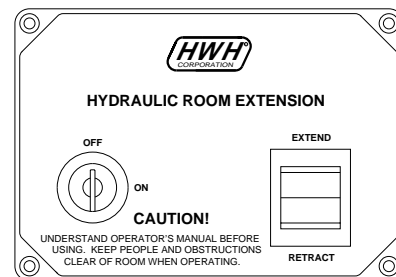

**Please read the entire HWH Operator's Manual before operating.*



Taking you to the next level.

(On I-80, Exit 267 South)

2096 Moscow Road | Moscow, Iowa 52760

Phone: (800)321-3494 or (563)724-3396 | Fax: (563)724-3408

Web: www.hwh.com

See Reverse Side For Specifications →

Specifications

The HWH® SpaceMaker® : Dual Cylinder "Level Out" Room Extension (With HWH Synchronizing Cylinder)

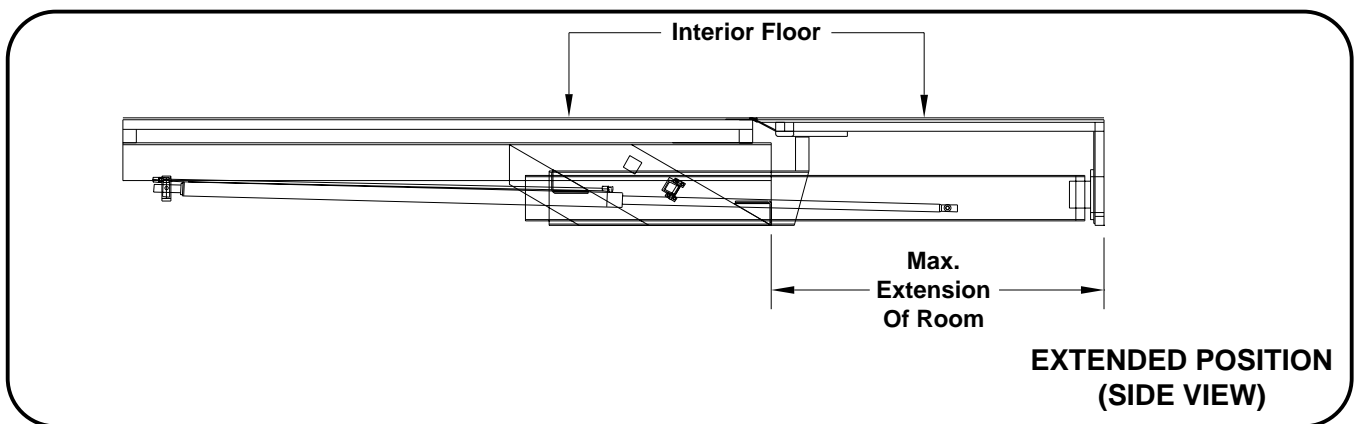
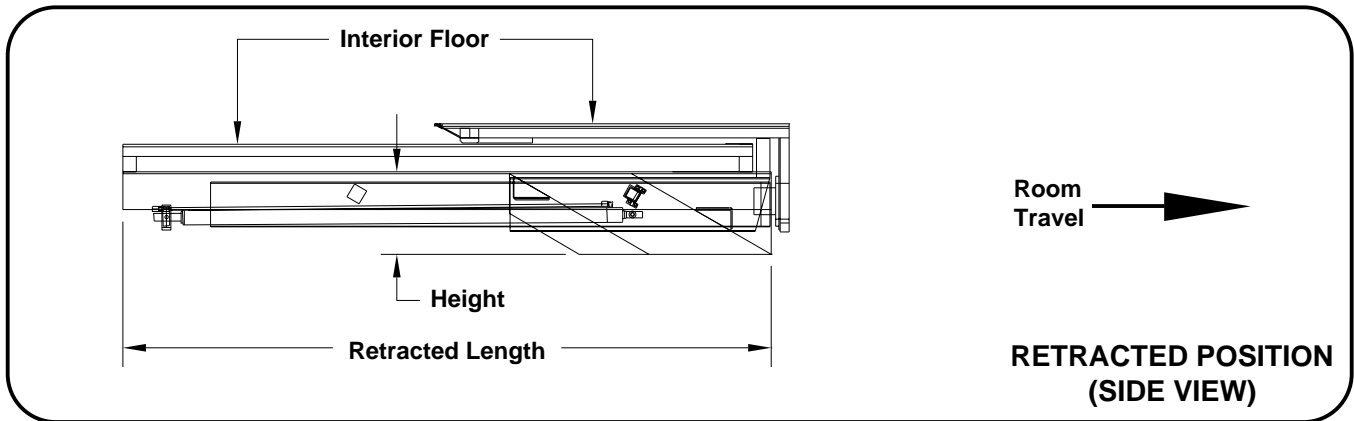

NOTE: SPECIFICATIONS VARY FOR DIFFERENT MODELS.

SPECIFICATIONS FOR SHOWN MODEL	
WEIGHTS (lbs.)	
Mechanism Assembly (2 Rails)	208.00
Synchronizing Cylinder	15.50
Pump *	14.20
Gross Weight *	237.70
DIMENSIONS (in.)	
Width (Each Rail)	8.00
Height (Each Rail)	9.40
Length (Retracted)	72.00
Max. Extension of Room	35.00
LOAD per ARM ** (lbs.)	500.00
FORCE of CYLINDER (lbs.)	
Max. Extending	2,100.00
Max. Retracting	2,100.00
PRIMARY APPLICATION	
Any Suitable Room	Below Floor

* If coach is equipped with an HWH Leveling System, pump is included.

** Load includes all occupants, cargo, room and permanent fixtures resting on room.